

Telecontrol Transformer TCT

General Operating, Maintenance and Installation Manual



IPCOMM GmbH

Gundstraße 15
D-91056 Erlangen

Phone: +49 9131 92076-0

Fax: +49 9131 92076-10

Internet: <http://www.ipcomm.de>

Email: info@ipcomm.de

Edition September 2010
Version 3.2.3



DIN EN ISO 9001:2008
Zertifikat: 01 100 040757

Index

1	INTRODUCTION	2
2	GENERAL SPECIFICATION	3
2.1	Application.....	3
2.2	Nomenclature	4
2.3	Operation	4
2.4	Mounting and Dismounting	5
2.5	Electrical Installation	6
2.5.1	<i>Circuit Diagram</i>	6
2.5.2	<i>Pin Allocation</i>	7
2.6	Electrical Commissioning	8
2.7	Maintenance	9
2.8	Scope of Delivery	10
3	APPENDIX A – TECHNICAL DATA SHEET	11
4	APPENDIX B – DECLARATION OF EEC COMPLIANCE	13

1 Introduction

All technical information, descriptions and illustrations contained in this Operating, Maintenance and Installation Manual remain our property and shall not be used otherwise than for operating this product, nor shall they be copied, reproduced or passed on to third parties or brought to their notice without our prior written consent.

The information represented in this manual is in keeping with current standards and is subject to later alterations.

This manual contains important instructions referring to safe installation, commissioning, operation and maintenance.

Read this manual carefully before starting up the Telecontrol Transformer and observe the instructions.

Please note that the Telecontrol Transformer has not been protected against the danger of lightning. If desired, the operator should implement appropriate protection measures.

Caution!

The Telecontrol Transformer is a class A device. This device can cause radio disturbances in residential buildings. In this case the operator might be obliged to carry out appropriate measures and take responsibility.

All trademarks and brand names contained in this user manual are for identification purposes only and can be owned by their respective holders.

Finally we want to draw your attention to the fact that any warranties with respect to the delivered goods will be invalid in the event that:

- Operation, servicing and maintenance are not carried out accurately according to the instructions; repairs are not carried out by our personnel or without our prior written consent.
- Commissioning is not carried out by our personnel or we have not given our approval for the commissioning or the commissioning is carried out by untrained personnel.
- The unit is used inadequately, incorrectly, negligently or inappropriately or for a purpose other than that originally intended.
- The serial number is removed from the product.

2 General Specification

2.1 Application

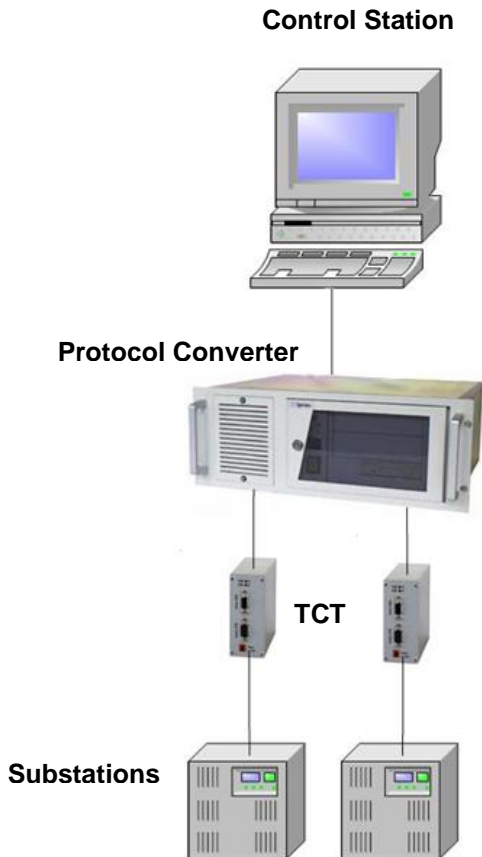

Fig. 2.1: Basic structure
Control station – Protocol Converter
TCT – Substation

The Telecontrol Transformer (TCT) is used for coupling bit synchronous or pulse length modulated, i.e. "non-asynchronous" protocols.

Figure 2.1 shows the basic structure between control station, protocol converter *ipConv* with TCT and substation.

The TCT is equipped with a μ -Controller responsible for converting data from or into the asynchronous format.

The TCT does not assume a higher protocol function, i.e. telegrams are transformed on a one-to-one basis.

In order to prevent delays in receiving or transmitting, the connection in the direction of the Protocol Converter operates at very high baud rates (max. 57.600 Baud).

Data transfer does not occur after a complete telegram has been received, but in smaller data blocks during reception.

The Telecontrol Transformer is fitted with a serial RS232 interface in both directions as a standard.

The serial interface towards the communication terminal equipment has been electrically isolated.

2.2 Nomenclature

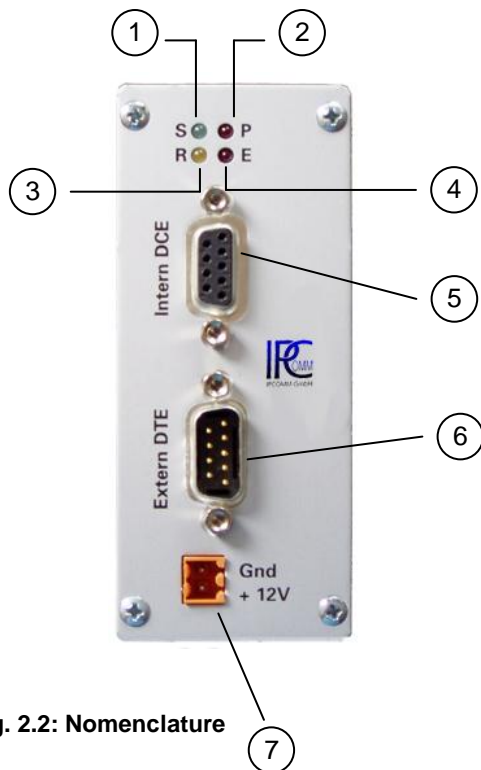

- (1) LED Transmission Indicator S (green)
- (2) LED Operational Indicator P (red)
- (3) LED Reception Indicator R (yellow)
- (4) LED Error Indicator E (red)
- (5) DB9 Socket (DCE)
- (6) DB9 Plug (DTE)
- (7) Connector for external power supply, + 12 V DC

Fig. 2.2: Nomenclature

2.3 Operation

The Telecontrol Transformer (protection class IP 40) has been designed for installation in a switch cabinet and is supplied with 12 V DC via an external power supply (optional).

In order to maintain operating function, greater variations in temperature should be avoided. An air-conditioned operating environment for the TCT is recommended.

Possible sources of interference, such as current inverters and power current lines near the Telecontrol Transformer, should be avoided.

Following conditions have to be observed:

- Temperature range: 0° C – 55° C
- Relative humidity: 5 % - 90 % **non-condensing**
- Installation as per IP 40, i.e. installation site and environment comply with the appropriate degree of protection.
- *The housing is not protected against the penetration of water!*
- The supply voltage must remain within the permissible voltage range (see technical data sheet)
- Precautionary measures must be taken in order to avoid excessively high mains voltage fluctuations.
- Mounting on electro conductive and grounded DIN Mounting Rail.

Note: Excessive voltages either fed directly via the power voltage or indirectly via data lines, mains power line or as a result of voltage excesses to the TCT might cause damage to the TCT. This situation must be avoided.

Important: The instructions necessary for the operation of the power supply included in the delivery can be found in the OMRON mains power supply operating manual enclosed, provided that this power supply is delivered by IPCOMM GmbH.

2.4 Mounting and Dismounting

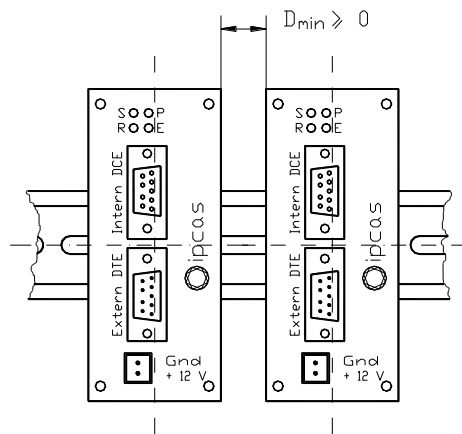

Fig. 2.4.1: Arrangement of TCT

No minimum distance D_{\min} need be observed if several Telecontrol Transformers are to be installed in a row.

The function of the Telecontrol Transformers is independent of their position. They can therefore be mounted in any desired position, fig. 2.4.1.

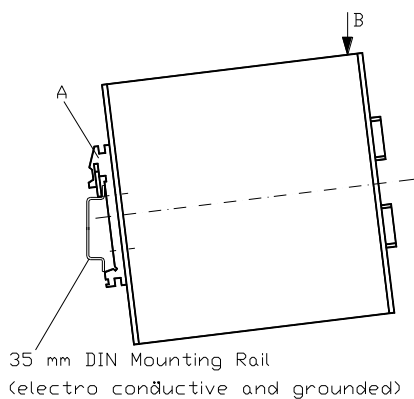

Fig. 2.4.2: Mounting the TCT

The Telecontrol Transformer is mounted on a 35 mm DIN Mounting Rail.

As per figure 2.4.2 opposite, clip A is putted on to the DIN Mounting Rail.

By pressing in the direction of the marked point B the Telecontrol Transformer snap into place.

The ground connection is completed via clip A directly to the DIN Mounting Rail.

It must be ensured that the DIN Mounting Rail is electro conductive and grounded.

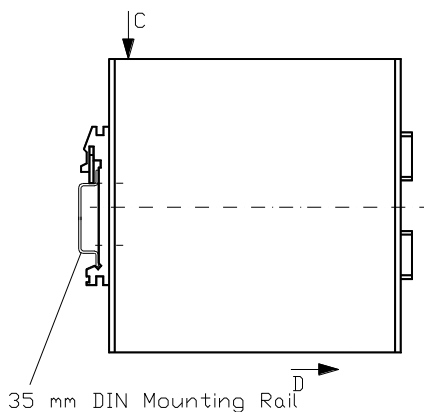

Fig. 2.4.3: Dismounting the TCT

For dismounting, press in the direction of the marked point C while pulling at the bottom of the Telecontrol Transformer in the direction D, fig. 2.4.3.

2.5 Electrical Installation

2.5.1 Circuit Diagram

The Telecontrol Transformer must be electrically connected as per the following circuit diagram, fig. 2.5.1. The operating voltage of the Telecontrol Transformer is + 12 V DC +/- 10 %.

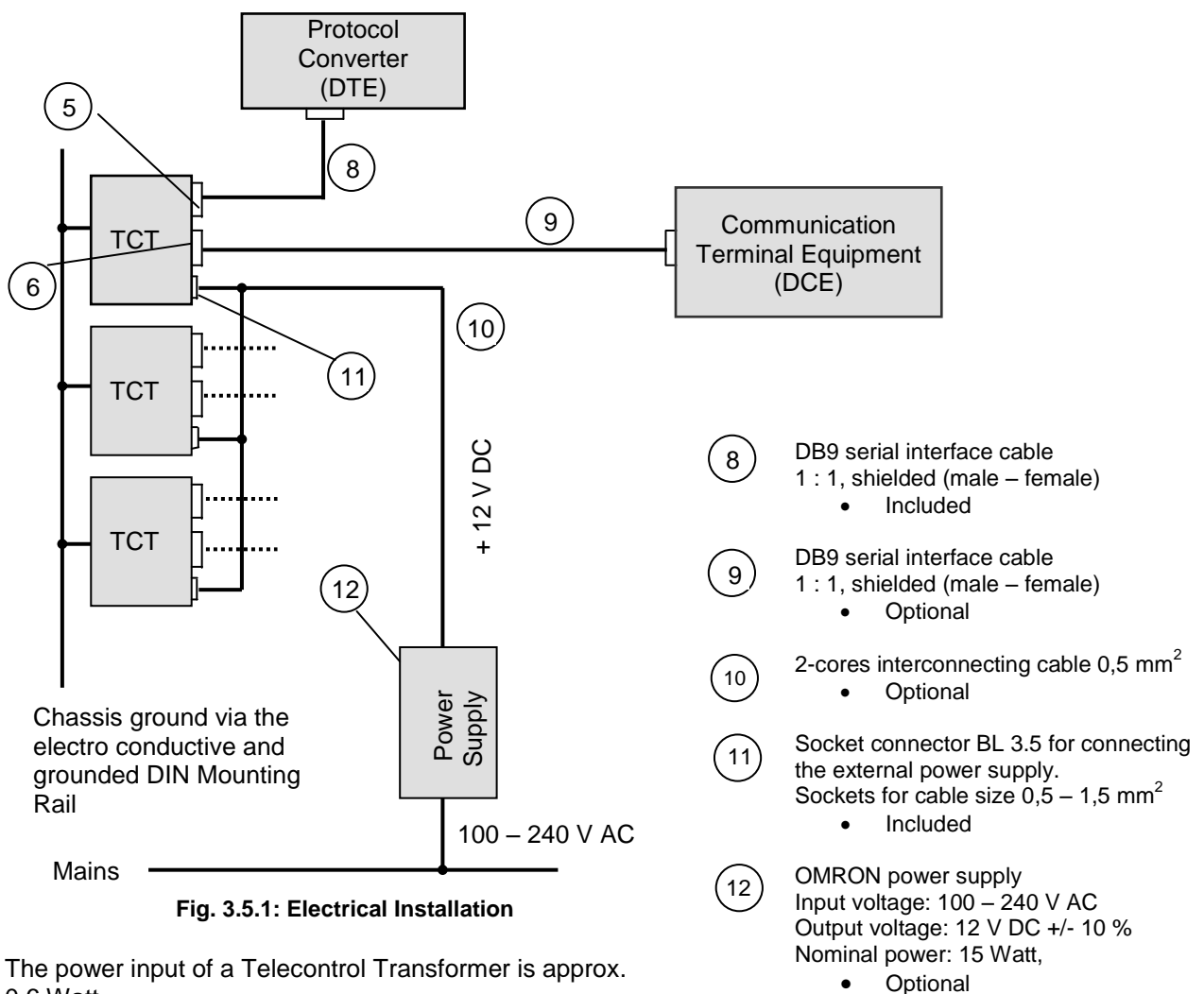

The power input of a Telecontrol Transformer is approx. 0.6 Watt.

The maximum number of Telecontrol Transformers to be connected in a parallel circuit is therefore limited by the maximum power supply.

Important: In order to comply with the regulations on electromagnetic compatibility data lines and the power supply cable must be as short as possible.

2.5.2 Pin Allocation

Figure 2.5.2 shows the pin allocation of the Telecontrol Transformer. The terminal pins marked with a * are required for communication.

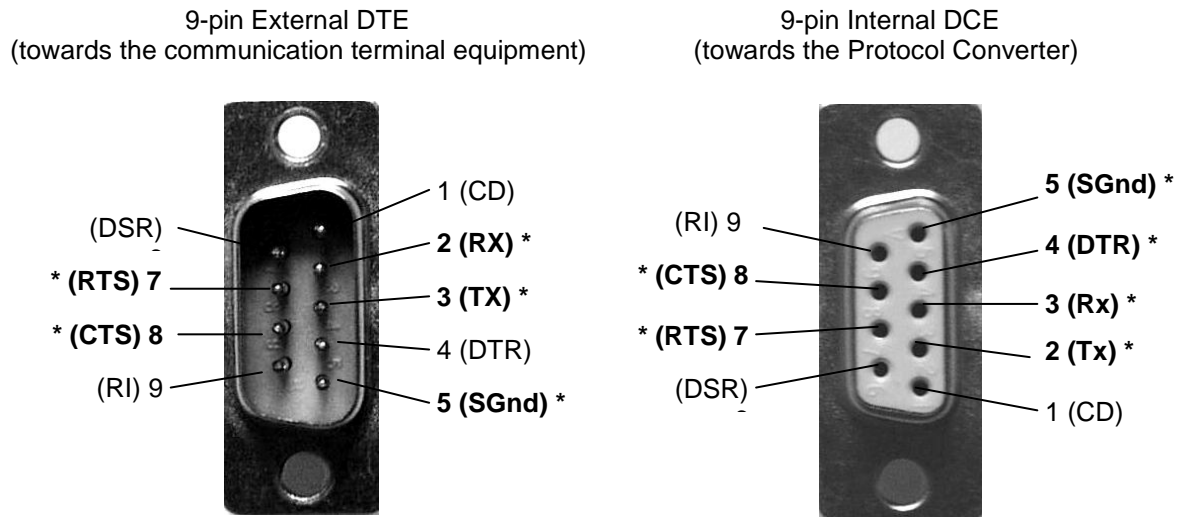

Fig. 2.5.2 TCT pin allocation

RTS: Request To Send
 CTS: Clear To Send
 DTR: Data Terminal Ready
 Rx: Receive Data
 Tx: Transmit Data
 SGnd: Signal Ground

2.6 Electrical Commissioning

After electrical installation of the Telecontrol Transformer as per circuit diagram 2.5.1, electrical commissioning can commence.

As soon as the Telecontrol Transformer is supplied with voltage all four LEDs will light up (function test of the LEDs).

Now the Protocol Converter is switched on.

Immediately on bootstrapping the Protocol Converter (default) or after starting the ipConv software (dependent on the configuration) the "DTR" signal is activated.

This extinguishes all four LEDs.

After initializing the Telecontrol Transformer by the Protocol Converter the following operational states can occur:

1. The red LED (P) "Operational Indicator" lights up.
The Telecontrol Transformer is ready to operate;
there is however no data waiting in line to be transmitted (open-circuit operation).
This LED is always lit up.
2. The yellow LED (R) "Reception Indicator" lights up.
Data are received from the external communication terminal equipment.
3. The green LED (S) "Transmission Indicator" lights up.
Data are sent to the external communication terminal equipment.
4. The red LED (E) "Error Indicator" lights up.
In this case a communication error (malfunction) has occurred.
5. The LEDs (P), (R), (S) and (E) light up.
A malfunction has occurred.

2.7 Maintenance

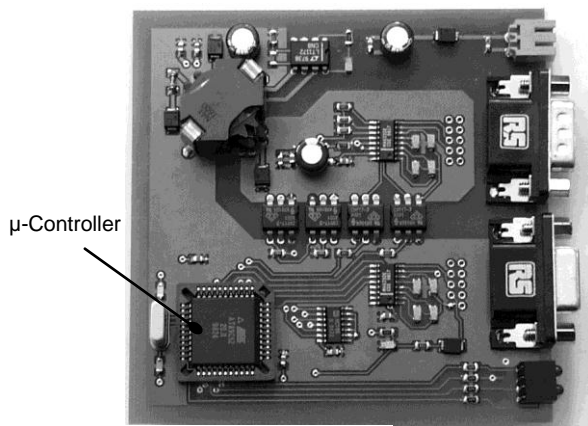

Fig. 2.7.1: Circuit board TCT

Generally the Telecontrol Transformer is maintenance-free.

Fig. 2.7.1 shows the assembled circuit board of the Telecontrol Transformer.
The heart of the circuit board is the μ -Controller.

Should it become necessary to exchange the μ -Controller, proceed as follows:

1. Disconnect the Telecontrol Transformer from the mains, detach the data lines.
2. After dismantling as per point 3.4, remove the four housing screws on the front panel of the Telecontrol Transformer.
3. The circuit board complete with the front panel is then pulled out of the housing.
4. The μ -Controller is removed by means of PLCC pliers, fig. 2.7.2. Apply the pliers in such a way that those parts of the pliers that are marked with an A correspond with the socket (see fig. 2.7.2 and 2.7.3). When inserting the new μ -Controller ensure that the slanted edge of the μ -Controller corresponds with the one of the socket.
Important: Any transfer of charges to the μ -Controller must be avoided.
5. Then press carefully the μ -Controller into the socket.
6. Push the circuit board back into the housing. Ensure that the correct mounting position is maintained (see figures 2.4.1 and 2.4.3).
Then tighten the 4 screws on the front panel.
7. After proper installation the Telecontrol Transformer can be put into operation again.

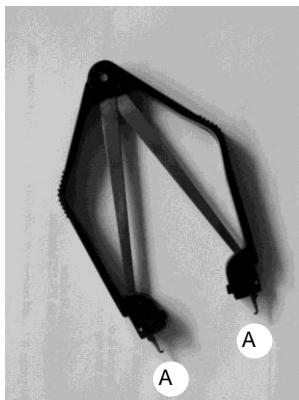

Fig. 2.7.2: PLCC pliers

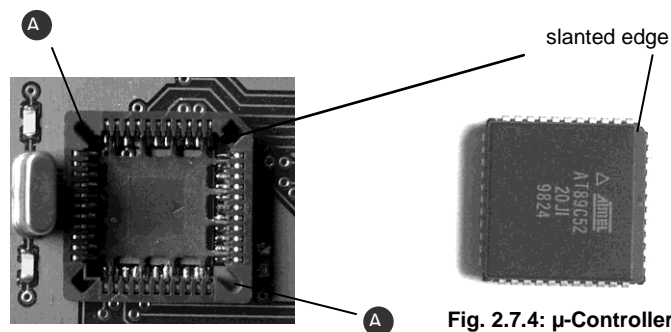

Fig. 2.7.3: Socket for μ -Controller



Fig. 2.7.4: μ -Controller

2.8 Scope of Delivery

- Telecontrol Transformer (TCT)
- Connecting cable for serial interfaces DB9 (TCT– PC), 1 : 1, shielded, male – female, length 1,8 m
- Socket connector BL 3,5

Optional:

- OMRON + 12 V DC power supply

3 Appendix A – Technical Data Sheet

Telecontrol Transformer – Technical Data

Interface in direction to the PC

- RS232 (RxD, TxD, Gnd) DCE
- DB9-connector
- Baud-rate max. 57.600 baud
- Asynchronous data format

Interface in direction to the data communication device

- RS232 (RxD, TxD, RTS, CTS, Gnd) DTE
- DB9 connector
- Baud-rate max. 2.400 baud (higher baud-rates in request)
- 4 in- and outputs (RxD, TxD, RTS, CTS) are optodecoupled in acc. to VDE 0884
- Insulation voltage 2 kV=

Diagnostic display

- 1 LED for function diagnosis
- 3 LEDs for data transmission (receiving, transmission and error)

Housing

- Aluminum, surface passivated

Assembly

- 35 mm DIN Mounting Rail

Dimension (without clip fastening)

- Width: 44 mm
- Height: 105 mm
- Depth: 103 mm

Power supply

- 12 V DC \pm 10 % external

Power input

- Approx. 0,6 W

Standards

- CE-certified

Operating Environment

- Temperature: 0° C to 55° C
- Relative humidity (non-condensing): 5 % to 90 %

4 Appendix B – Declaration of EEC Compliance

Declaration of EEC Compliance

For the following product

Telecontrol Transformer (TCT)

it is hereby confirmed that it complies with the main specifications laid down in the Council Guidelines on Harmonising the Statutory Regulations of the Member States for Electromagnetic Compatibility (89/336/EWG).

Any changes to the said Telecontrol Transformer not authorised by this company invalidates this declaration.

The evaluation of this product for electromagnetic compatibility was carried out in accordance with the following standards

EN 55022/1998

EN 50082-2/1997

Place/Date/Manufacturer signature: Erlangen, 31 August 2004

Position of signatory: Managing Director, Artur Votteler

