

# Industrial PC IPC191V3 (Linux OS) IPC191V3WIN (Windows OS)

## General Operating, Maintenance and Installation Manual

### Hardware Platform Protocol Converter



IPCOMM GmbH

Gundstraße 15  
D-91056 Erlangen

Phone: +49 9131 92076-0

Fax: +49 9131 92076-10

Internet: <http://www.ipcomm.de>

Email: [info@ipcomm.de](mailto:info@ipcomm.de)

Edition March 2012  
Version 2.2



DIN EN ISO 9001:2008  
Zertifikat: 01 100 040757

# Index

<b>1</b>	<b>INTRODUCTION.....</b>	<b>2</b>
<b>2</b>	<b>HARDWARE DESCRIPTION .....</b>	<b>3</b>
2.1	GENERAL.....	3
2.2	HARDWARE COMPONENTS.....	4
2.2.1	<i>Mainboard.....</i>	4
2.2.2	<i>CPU-Module RS-232 Interfaces.....</i>	5
2.2.3	<i>8-Port RS-232 Communication Board (RS-232 Interfaces for remote communication)....</i>	5
2.2.4	<i>4-Port RS-232 Communication Board (RS-232 Interfaces for remote communication)....</i>	6
2.2.5	<i>Ethernet Interfaces.....</i>	6
2.2.6	<i>CompactFlash.....</i>	7
2.2.7	<i>CMOS Lithium Battery.....</i>	7
2.2.8	<i>CPU LED.....</i>	8
2.2.9	<i>Power Supply.....</i>	9
2.2.9.1	AC Power Supply.....	9
2.2.9.2	DC Power Supply.....	9
<b>3</b>	<b>INTERFACE CONFIGURATION.....</b>	<b>10</b>
3.1	VARIANT A.....	10
3.2	VARIANT B.....	11
3.3	VARIANT C.....	12
3.4	VARIANT E.....	12
3.5	VARIANT E3.....	13
3.6	VARIANT E2.....	13
3.7	VARIANT E2M.....	14
3.8	VARIANT F.....	15
3.9	VARIANT L.....	16
3.10	VARIANT P.....	16
<b>4</b>	<b>TECHNICAL DATA .....</b>	<b>17</b>
<b>5</b>	<b>APPENDIX.....</b>	<b>20</b>
5.1	BACKUP, RESTORE (ONLY FOR INDUSTRIAL PCs WITH WINDOWS XP PROFESSIONAL OS – IPC191V3WIN).....	20
5.1.1	<i>Restoration / Reinstallation.....</i>	20
5.1.2	<i>Backup.....</i>	20
5.2	IPC191V3 CAD DRAWING.....	20

# 1 Introduction

All technical information, descriptions and illustrations contained in this Operating, Maintenance and Installation Manual remain our property and shall not be used otherwise than for operating this System, nor shall they be copied, reproduced or passed on to third parties or brought to their notice without our prior written consent.

The information represented in this manual is in keeping with current standards and is subject to later alterations.

This manual contains important instructions referring to safe installation, commissioning, operation and maintenance.

Read this manual carefully before starting up the protocol converter and observe the instructions.

In order to comply with the guidelines for electro-magnetic compatibility in industrial PCs (or other variants) only CE-certified components are used in compliance with project-specific requirements.

It is to be noted that the Protocol Converter (IPC191V3) has not been protected against lightning and the operator should, *if desired*, take appropriate protective precautions.

All trademarks and brand names contained in this user manual are for identification purposes only and can be owned by their respective holders.

Finally we want to draw your attention to the fact that any warranties with respect to delivered goods will be invalid in the event that:

- Operation, servicing and maintenance are not carried out accurately according to the instructions; repairs are not carried out by our personnel or without our prior written consent.
- Commissioning is not carried out by our personnel or we have not given our approval for the commissioning or the commissioning is carried out by untrained personnel.
- The unit is used inadequately, incorrectly, negligently or inappropriately or for a purpose other than that originally intended.
- The serial number is removed from the product.

**For your protection, observe the following safety precautions when setting up your equipment:**

- Follow all cautions and instructions marked on the equipment.
- Ensure that the voltage and frequency of your power source match the voltage and frequency inscribed on the equipment's electrical rating label.
- Never push objects of any kind through openings in the equipment. Dangerous voltages may be present. Conductive foreign objects could produce a short circuit that could cause fire, electric shock, or damage to your equipment.
- The industrial PC must be mounted on an equipment carrier (1U) in a 19" rack. A free floating or unilateral mounting may cause defects.

*All trademarks or brand marks mentioned in this document are used for identification and are property of their respective owners.*

## 2 Hardware Description

### 2.1 General

As hardware platform for the protocol converter a 19" industrial PC is used. This solution offers a high degree on flexibility, performance and reliability.

Mounting and intensive tests of the industrial PC are done in our company. Before and after a 48 hour burn-in test each device must run through a complete function test.

All components are cooled passively. Only if critical system temperatures have been reached two independent housing fans are switched on automatically. Important for the selection of our components are particular items like quality, availability and a high durability.

The industrial PC consists of a 19" chassis (1U) with an integrated Dual PCI riser card for inserting the appropriate cards.

The mains power supply are 90 – 264 V AC, 127 – 373 V DC auto range, optional 10 – 36 V DC power supply (other on request).

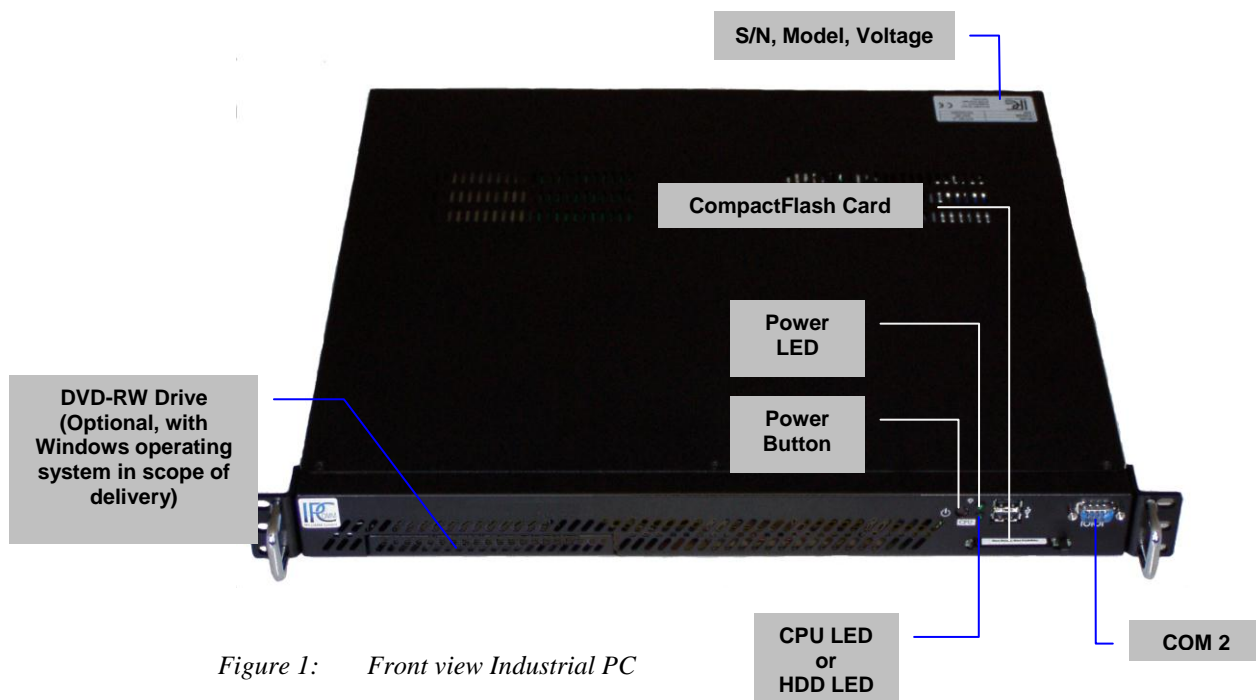

Figure 1: Front view Industrial PC

Figure 2 shows the reverse side of our Industrial PC. The pin assignments vary according to execution. Overview of the different models can be found in chapter 3 Interface Configuration.

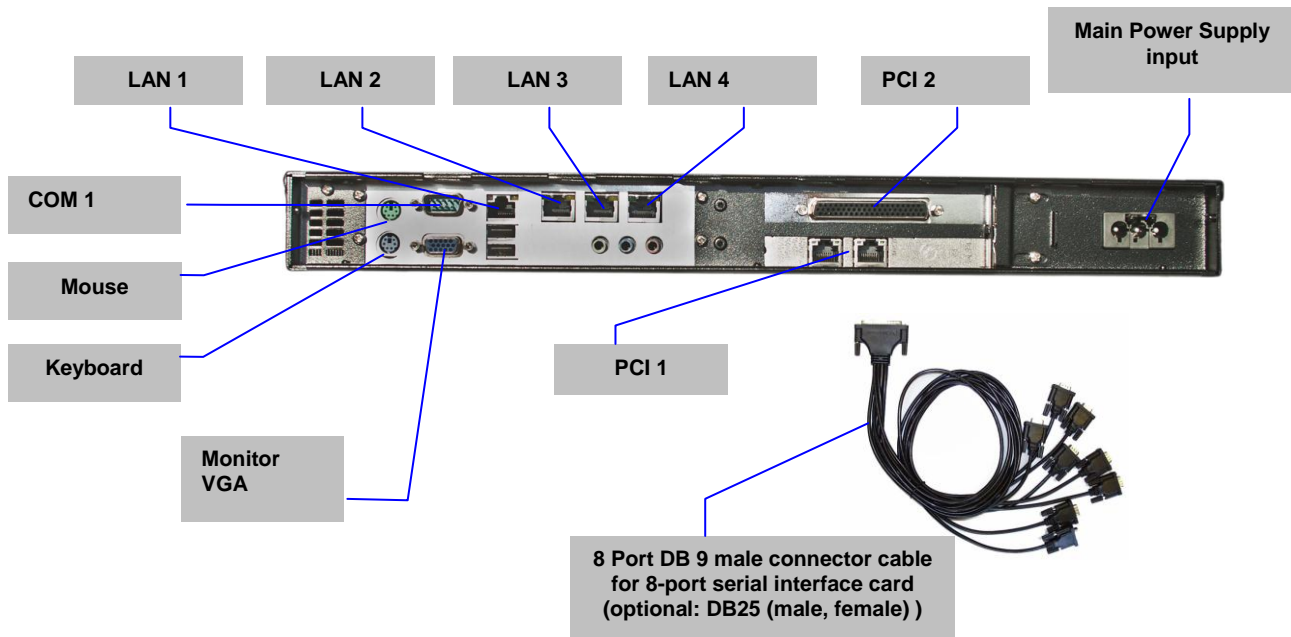

Figure 2: Overview Interfaces (example shows variant [E2M](#) with 8-port serial interface card (PCI 2) and 2x Ethernet (PCI 1))

## 2.2 Hardware Components

### 2.2.1 Mainboard

The Mini-ITX Mainboard is an ultra-compact x86 platform with all the necessary interfaces. Its heart consists of a fanless highly efficient embedded VIA processor. The mainboard provides one DIMM slot for DDRII memory modules and supports up to 2GB system memory.

The following interfaces are provided by the CPU module:

- 3 x RS-232 Interface (model-specific)
- 2 x SATA
- 1 x LAN 10/100/1000 Mbps BaseT (RJ45), 3x LAN 10/100 Mbps BaseT (RJ45)
- EIDE Interface
- VGA Interface
- Keyboard- / Mouse Port
- USB
- PCI

## 2.2.2 CPU-Module RS-232 Interfaces

The installed mainboard provides 3 serial interfaces. However, depending on the model these interfaces are completely or only partly available at the chassis. COM3 interface is active but reserved for internal purpose and cannot be used.

This interface type is used for COM 1

SERIAL PORT RS-232 DTE DB9 male connector			
	Pin	Direction	Description
	1	INPUT	DCD Data Carrier Detect
	2	INPUT	RXD Receive Data
	3	OUTPUT	TXD Transmit Data
	4	OUTPUT	DTR Data Terminal Ready
	5		GND Ground
	6	INPUT	DSR Data Set Ready
	7	OUTPUT	RTS Request To Send
	8	INPUT	CTS Clear To Send
	9	INPUT	RI Ring Indicator

Figure 3: Pin Assignment of DB9 Interface (Computer) COM1-COM2

## 2.2.3 8-Port RS-232 Communication Board (RS-232 Interfaces for remote communication)

Depending on the model each IPC191V3 can be equipped with up to two 8-port serial interface cards. The following pin assignment is realized with an 8-port DB9 male connector cable (see Figure 2: Overview Interfaces). Other cables (e.g. DB25) are possible on request.

SERIAL PORT RS-232 DTE DB9 male connector			
	Pin	Direction	Description
	1	INPUT	DCD Data Carrier Detect
	2	INPUT	RXD Receive Data
	3	OUTPUT	TXD Transmit Data
	4	OUTPUT	DTR Data Terminal Ready
	5		GND Ground
	6	INPUT	DSR Data Set Ready
	7	OUTPUT	RTS Request To Send
	8	INPUT	CTS Clear To Send
	9		

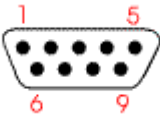
Figure 4: Pin Assignment of DB9 interface (Communication Board)

## 2.2.4 4-Port RS-232 Communication Board (RS-232 Interfaces for remote communication)

Depending on the model each IPC191V3 can be equipped with up to two 4-port serial interface cards.

Pin	Direction	Description
1	INPUT	DSR Data Set Ready
2	OUTPUT	RTS Request To Send
3		GND Ground
4	OUTPUT	TXD Transmit Data
5	INPUT	RXD Receive Data
6	INPUT	DCD Data Carrier Detect
7	INPUT	CTS Clear To Send
8	OUTPUT	DTR Data Terminal Ready

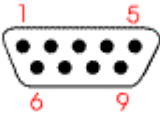
Figure 5: Pin Assignment of RJ45 interface (Communication Board)

## 2.2.5 Ethernet Interfaces

The industrial PC features up to four Ethernet interfaces generally. The connection is set up via one 10/100/1000 Mbps BaseT (RJ45) and three 10/100 Mbps BaseT (RJ45) interfaces. Further interfaces with 10/100 Mbps or 10/100/1000 Mbps BaseT are possible on request.

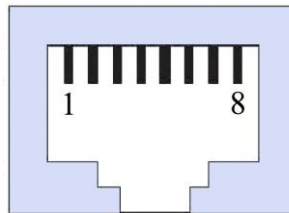

Figure 6: Pin Assignment RJ45 interface

## 2.2.6 CompactFlash

The CompactFlash card serves as a mass storage device, i.e. for storing the operating system, the applications and configuration data. As a result the disadvantages involved with the use of a rotating hard disk are avoided, thus improving the reliability of the system substantially since a CompactFlash has an MTBF of at least 1,000,000 hours.

The CompactFlash adapter is simply connected to the IDE bus of the CPU module and treated just like a hard disk.

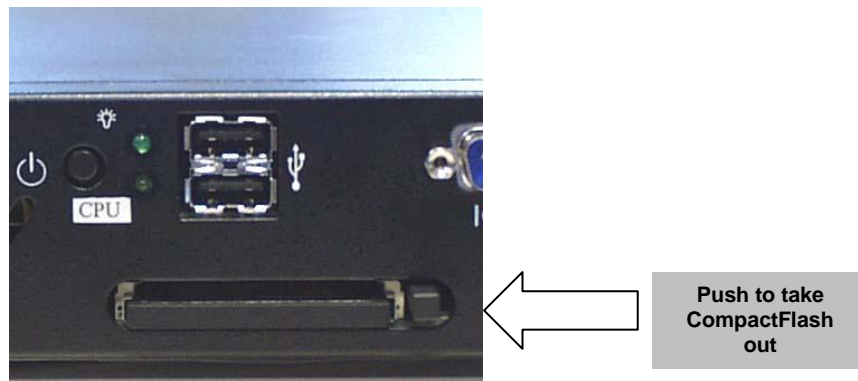

Figure 7: CompactFlash Adapter

When the power supply is switched off the CompactFlash card can simply be taken out or inserted enabling a quick change to different hardware.

## 2.2.7 CMOS Lithium Battery

The onboard CMOS RAM stores system configuration data and has an onboard battery power supply. The long-life Lithium battery has normally a lifetime of at least 5 years.

If the CMOS battery is empty and the CMOS information has been deleted, the CMOS-RAM is programmed by the BIOS with default settings. The converter can be operated faultlessly even if the CMOS RAM is not provided by the battery. After the battery has been changed only time and date must be input.

For opening the case 6 screws on the top must be removed. The battery holder is soldered in the Mainboard and well visible.

**Attention:** Open-frame power supplies are used. Because of this, the process should be carried out only by experienced electronic engineers. The device must be completely disconnected from any power supply. Before opening please push the power button (without electricity supply) several times to eliminate residual voltages of the power supply.

Battery replacement must be carried out by qualified specialists.

**CAUTION!** Incorrect replacement might cause the danger of explosion. Replace the battery exclusively by the same type (**3 V DC, CR2032**). Used batteries are to be disposed absolutely in accordance with the manufacturer's instructions.

**Please pay attention to the correct polarity!**

## 2.2.8 CPU LED

The CPU LED shows the states of conversion software and operating system.

Following figure shows all possible indications:

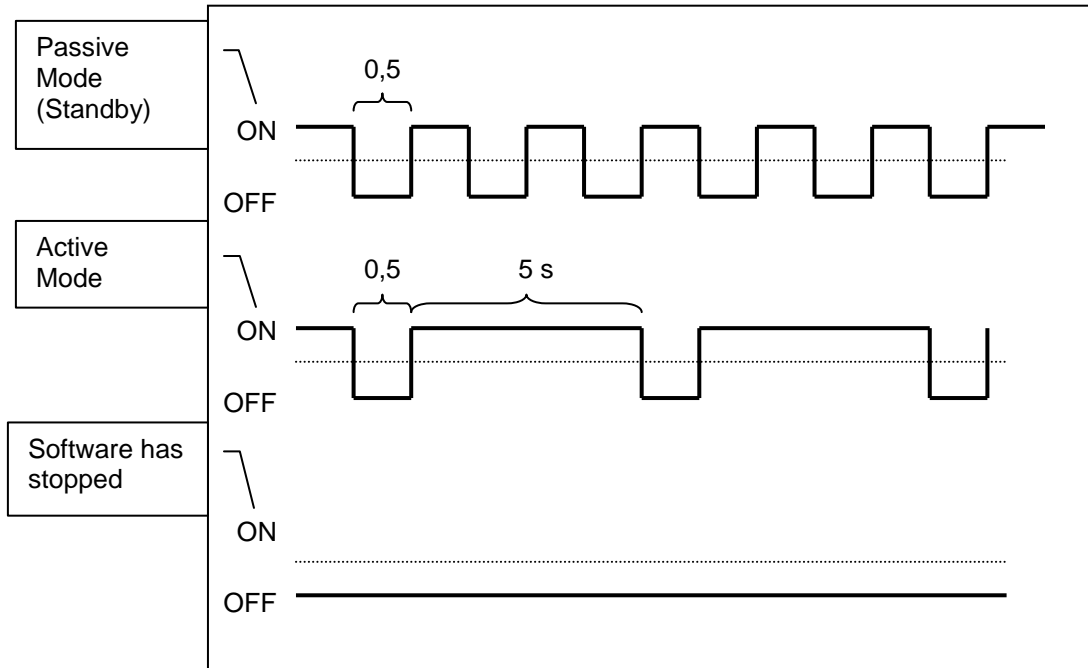

Figure 8: CPU-LED indications

**Attention!** If the IPC191V3 is ordered without **ipConv** software and not as a replacement for an existing project, an HDD-Activity LED is installed instead of the CPU-LED! The device name is then labeled with an additional "**-H**", for example: "IPC191V3-**H**"

## 2.2.9 Power Supply

Power supplies with different input voltages can be used in the IPC191V3. Please pay attention to the correct polarity and input voltage. The input voltage of the respective device is labeled on top of the housing (see Figure 1: Front view Industrial PC).

### 2.2.9.1 AC Power Supply

By using AC voltages a specific power supply cable (see figure below) is supplied. Please use this cable exclusively.



Figure 9: Power Cable

### 2.2.9.2 DC Power Supply

By using DC voltages only a male connector is supplied. This connector has to be used. By connecting the cable with the male connector the correct polarity must be kept. The wire cross-section must be at least 1,5 mm<sup>2</sup>.

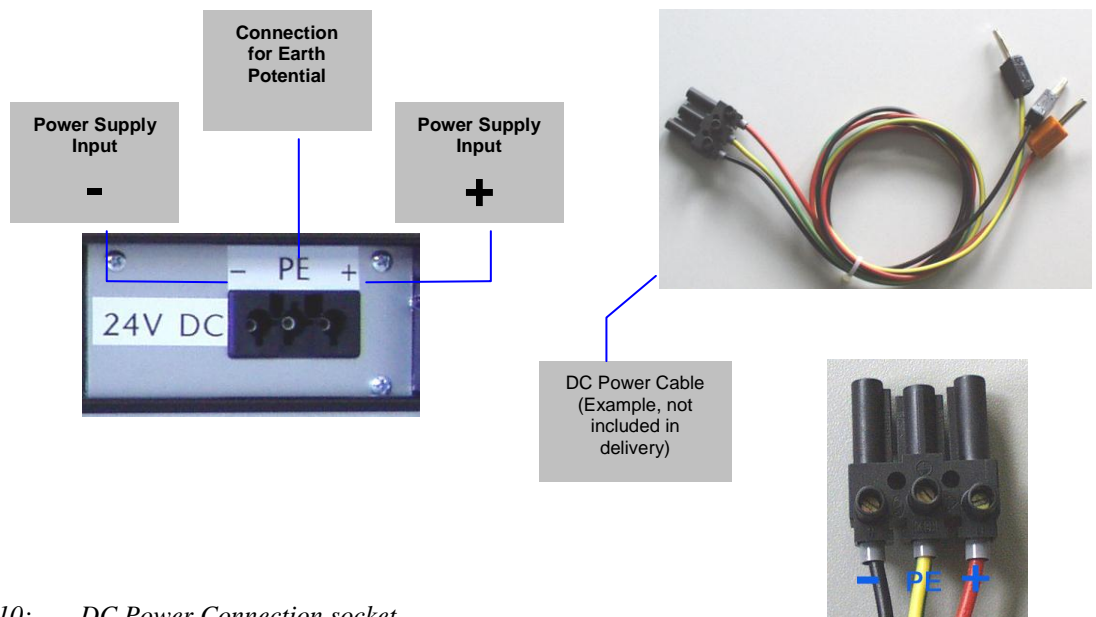

Figure 10: DC Power Connection socket

### 3 Interface Configuration

The following tables represent the configuration of the individual interfaces of miscellaneous variants.

#### 3.1 Variant A

Assembly	Linux Device	I/O port	IRQ	Label	Connector
Mainboard	ttyS0	3F8	4	IOIOI (Chassis rear)	DB9ST
	ttyS1	2F8	3	IOIOI (Chassis front)	DB9ST
	ttyS2	3E8	5	CPU (Diagnose)	NOT Connected
	eth0	PCI (Onboard)	Auto	LAN1	RJ45
	eth1	PCI (Onboard)	Auto	LAN2	RJ45
	eth2	PCI (Onboard)	Auto	LAN3	RJ45
	eth3	PCI (Onboard)	Auto	LAN4	RJ45
UART Adapter 8X	ttyS3	PCI (Slot 2)	Auto	COM4	DB9ST
	ttyS4	PCI (Slot 2)	Auto	COM5	DB9ST
	ttyS5	PCI (Slot 2)	Auto	COM6	DB9ST
	ttyS6	PCI (Slot 2)	Auto	COM7	DB9ST
	ttyS7	PCI (Slot 2)	Auto	COM8	DB9ST
	ttyS8	PCI (Slot 2)	Auto	COM9	DB9ST
	ttyS9	PCI (Slot 2)	Auto	COM10	DB9ST
	ttyS10	PCI (Slot 2)	Auto	COM11	DB9ST

### 3.2 Variant B

Assembly	Linux Device	I/O port	IRQ	Label	Connector
Mainboard	ttyS0	3F8	4	IOIOI (Chassis rear)	DB9ST
	ttyS1	2F8	3	IOIOI (Chassis front)	DB9ST
	ttyS2	3E8	5	CPU (Diagnose)	NOT Connected
	eth0	PCI (Onboard)	Auto	LAN1	RJ45
	eth1	PCI (Onboard)	Auto	LAN2	RJ45
	eth2	PCI (Onboard)	Auto	LAN3	RJ45
	eth3	PCI (Onboard)	Auto	LAN4	RJ45
UART Adapter 8X	ttyS3	PCI (Slot 1)	Auto	COM4	DB9ST
	ttyS4	PCI (Slot 1)	Auto	COM5	DB9ST
	ttyS5	PCI (Slot 1)	Auto	COM6	DB9ST
	ttyS6	PCI (Slot 1)	Auto	COM7	DB9ST
	ttyS7	PCI (Slot 1)	Auto	COM8	DB9ST
	ttyS8	PCI (Slot 1)	Auto	COM9	DB9ST
	ttyS9	PCI (Slot 1)	Auto	COM10	DB9ST
	ttyS10	PCI (Slot 1)	Auto	COM11	DB9ST
UART Adapter 8X	ttyS11	PCI (Slot 2)	Auto	COM12	DB9ST
	ttyS12	PCI (Slot 2)	Auto	COM13	DB9ST
	ttyS13	PCI (Slot 2)	Auto	COM14	DB9ST
	ttyS14	PCI (Slot 2)	Auto	COM15	DB9ST
	ttyS15	PCI (Slot 2)	Auto	COM16	DB9ST
	ttyS16	PCI (Slot 2)	Auto	COM17	DB9ST
	ttyS17	PCI (Slot 2)	Auto	COM18	DB9ST
	ttyS18	PCI (Slot 2)	Auto	COM19	DB9ST

### 3.3 Variant C

Assembly	Linux Device	I/O port	IRQ	Label	Connector
Mainboard	ttyS0	3F8	4	IOIOI (Chassis rear)	DB9ST
	ttyS1	2F8	3	IOIOI (Chassis front)	DB9ST
	ttyS2	3E8	5	CPU (Diagnose)	NOT Connected
	eth0	PCI (Onboard)	Auto	LAN1	RJ45
	eth1	PCI (Onboard)	Auto	LAN2	RJ45
	eth2	PCI (Onboard)	Auto	LAN3	RJ45
	eth3	PCI (Onboard)	Auto	LAN4	RJ45
Ethernet Adapter 1X	eth4	PCI (Slot 1)	Auto	LAN5	RJ45
UART Adapter 8X	ttyS3	PCI (Slot 2)	Auto	COM4	DB9ST
	ttyS4	PCI (Slot 2)	Auto	COM5	DB9ST
	ttyS5	PCI (Slot 2)	Auto	COM6	DB9ST
	ttyS6	PCI (Slot 2)	Auto	COM7	DB9ST
	ttyS7	PCI (Slot 2)	Auto	COM8	DB9ST
	ttyS8	PCI (Slot 2)	Auto	COM9	DB9ST
	ttyS9	PCI (Slot 2)	Auto	COM10	DB9ST
	ttyS10	PCI (Slot 2)	Auto	COM11	DB9ST

### 3.4 Variant E

Assembly	Linux Device	I/O port	IRQ	Label	Connector
Mainboard	ttyS0	3F8	4	IOIOI (Chassis rear)	DB9ST
	ttyS1	2F8	3	IOIOI (Chassis front)	DB9ST
	ttyS2	3E8	5	CPU (Diagnose)	NOT Connected
	eth0	PCI (Onboard)	Auto	LAN1	RJ45
	eth1	PCI (Onboard)	Auto	LAN2	RJ45
	eth2	PCI (Onboard)	Auto	LAN3	RJ45
	eth3	PCI (Onboard)	Auto	LAN4	RJ45
Ethernet Adapter 1X	eth4	PCI (Slot 1)	Auto	LAN5	RJ45
Ethernet Adapter 1X	eth5	PCI (Slot 2)	Auto	LAN6	RJ45

### 3.5 Variant E3

Assembly	Linux Device	I/O port	IRQ	Label	Connector
Mainboard	ttyS0	3F8	4	IOIOI (Chassis rear)	DB9ST
	ttyS1	2F8	3	IOIOI (Chassis front)	DB9ST
	ttyS2	3E8	5	CPU (Diagnose)	NOT Connected
	eth0	PCI (Onboard)	Auto	LAN1	RJ45
	eth1	PCI (Onboard)	Auto	LAN2	RJ45
	eth2	PCI (Onboard)	Auto	LAN3	RJ45
	eth3	PCI (Onboard)	Auto	LAN4	RJ45
Ethernet Adapter 1X	eth4	PCI (Slot 2)	Auto	LAN5	RJ45

### 3.6 Variant E2

Assembly	Linux Device	I/O port	IRQ	Label	Connector
Mainboard	ttyS0	3F8	4	IOIOI (Chassis rear)	DB9ST
	ttyS1	2F8	3	IOIOI (Chassis front)	DB9ST
	ttyS2	3E8	5	CPU (Diagnose)	NOT Connected
	eth0	PCI (Onboard)	Auto	LAN1	RJ45
	eth1	PCI (Onboard)	Auto	LAN2	RJ45
	eth2	PCI (Onboard)	Auto	LAN3	RJ45
	eth3	PCI (Onboard)	Auto	LAN4	RJ45
Ethernet Adapter 2X	eth4	PCI (Slot 1)	Auto	LAN5	RJ45
	eth5	PCI (Slot 1)	Auto	LAN6	RJ45

### 3.7 Variant E2M

Assembly	Linux Device	I/O port	IRQ	Label	Connector
Mainboard	ttyS0	3F8	4	IOIOI (Chassis rear)	DB9ST
	ttyS1	2F8	3	IOIOI (Chassis front)	DB9ST
	ttyS2	3E8	5	CPU (Diagnose)	NOT Connected
	eth0	PCI (Onboard)	Auto	LAN1	RJ45
	eth1	PCI (Onboard)	Auto	LAN2	RJ45
	eth2	PCI (Onboard)	Auto	LAN3	RJ45
	eth3	PCI (Onboard)	Auto	LAN4	RJ45
Ethernet Adapter 2X	eth4	PCI (Slot 1)	Auto	LAN5	RJ45
	eth5	PCI (Slot 1)	Auto	LAN6	RJ45
UART Adapter 8X	ttyS3	PCI (Slot 2)	Auto	COM4	DB9ST
	ttyS4	PCI (Slot 2)	Auto	COM5	DB9ST
	ttyS5	PCI (Slot 2)	Auto	COM6	DB9ST
	ttyS6	PCI (Slot 2)	Auto	COM7	DB9ST
	ttyS7	PCI (Slot 2)	Auto	COM8	DB9ST
	ttyS8	PCI (Slot 2)	Auto	COM9	DB9ST
	ttyS9	PCI (Slot 2)	Auto	COM10	DB9ST
	ttyS10	PCI (Slot 2)	Auto	COM11	DB9ST

### 3.8 Variant F

Assembly	Linux Device	I/O port	IRQ	Label	Connector
Mainboard	ttyS0	3F8	4	IOIOI (Chassis rear)	DB9ST
	ttyS1	2F8	3	IOIOI (Chassis front)	DB9ST
	ttyS2	3E8	5	CPU (Diagnose)	NOT Connected
	eth0	PCI (Onboard)	Auto	LAN1	RJ45
	eth1	PCI (Onboard)	Auto	LAN2	RJ45
	eth2	PCI (Onboard)	Auto	LAN3	RJ45
	eth3	PCI (Onboard)	Auto	LAN4	RJ45
UART Adapter 4X	ttyS3	PCI (Slot 1)	Auto	COM4	RJ45
	ttyS4	PCI (Slot 1)	Auto	COM5	RJ45
	ttyS5	PCI (Slot 1)	Auto	COM6	RJ45
	ttyS6	PCI (Slot 1)	Auto	COM7	RJ45
UART Adapter 4X	ttyS11	PCI (Slot 2)	Auto	COM12	RJ45
	ttyS12	PCI (Slot 2)	Auto	COM13	RJ45
	ttyS13	PCI (Slot 2)	Auto	COM14	RJ45
	ttyS14	PCI (Slot 2)	Auto	COM15	RJ45

The COM ports of the UART adapter are configured as follows:

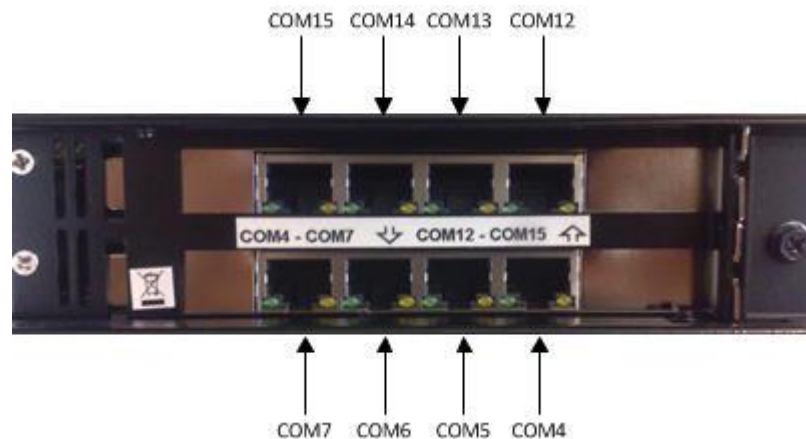

Figure 11: UART COM port configuration

### 3.9 Variant L

Assembly	Linux Device	I/O port	IRQ	Label	Connector
Mainboard	ttyS0	3F8	4	IOIOI (Chassis rear)	DB9ST
	ttyS1	2F8	3	IOIOI (Chassis front)	DB9ST
	ttyS2	3E8	5	CPU (Diagnose)	NOT Connected
	eth0	PCI (Onboard)	Auto	LAN1	RJ45
	eth1	PCI (Onboard)	Auto	LAN2	RJ45
	eth2	PCI (Onboard)	Auto	LAN3	RJ45
	eth3	PCI (Onboard)	Auto	LAN4	RJ45

### 3.10 Variant P

Assembly	Linux Device	I/O port	IRQ	Label	Connector
Mainboard	ttyS0	3F8	4	IOIOI (Chassis rear)	DB9ST
	ttyS1	2F8	3	IOIOI (Chassis front)	DB9ST
	ttyS2	3E8	5	CPU (Diagnose)	NOT Connected
	eth0	PCI (Onboard)	Auto	LAN1	RJ45
	eth1	PCI (Onboard)	Auto	LAN2	RJ45
	eth2	PCI (Onboard)	Auto	LAN3	RJ45
	eth3	PCI (Onboard)	Auto	LAN4	RJ45
Profibus Adapter 1X		PCI (Slot 1)	Auto	Profibus	Profibus
UART Adapter 8X	ttyS3	PCI (Slot 2)	Auto	COM4	DB9ST
	ttyS4	PCI (Slot 2)	Auto	COM5	DB9ST
	ttyS5	PCI (Slot 2)	Auto	COM6	DB9ST
	ttyS6	PCI (Slot 2)	Auto	COM7	DB9ST
	ttyS7	PCI (Slot 2)	Auto	COM8	DB9ST
	ttyS8	PCI (Slot 2)	Auto	COM9	DB9ST
	ttyS9	PCI (Slot 2)	Auto	COM10	DB9ST
	ttyS10	PCI (Slot 2)	Auto	COM11	DB9ST

## 4 Technical Data

### Chassis

- 19" rack mount chassis (1U)
- Dual PCI riser card
- The Industrial PC doesn't have any CPU- and Power supply fan. The hardware is equipped with two passive chassis fans which are switched on only if a certain CPU temperature and system temperature respectively has been exceeded (configurable).

### MTBF

> 100,000h

### Power Supply AC

- Fanless
- 90 – 264 V AC, 127 – 373 V DC autorange
- Input frequency: 47 – 63 Hz
- Hold up time:  $\geq 20$  msec, 230 VAC
- Power consumption: max. 50 W (depending on the used type)
- CE/TÜV certified (EN 60950-1, UL 60950-1)

### Power Supply DC (optional)

- Fanless
- 10-36 V DC
- Hold up time: >1 msec at +24 VDC and rated load
- Power consumption: max. 50 W (depending on the used type)
- CE/TÜV certified (UL / EN 60950-1)

### Mainboard

- VIA Nano 1 GHz, fanless CPU (up to 3x faster than IPC191V2 CPU)
- DDR2 RAM max. 2 GB
- IDE interface
- SATA interface
- 2 x serial ports
- Real-time clock/calendar
- 1 x RJ45 10/100/1000BaseT LAN interface, 3 x RJ45 10/100BaseT LAN interface onboard, more on request (over PCI)
- 4 x USB 2.0 (two at front side, two at back side), more on request
- RAID SATA functionality (RAID Level 0 or RAID Level 1)

### Serial Cards

- Up to sixteen serial RS-232 ports
- DB9 male connectors, optional RJ45, DB25 (male, female)
- Baud rate 50 bps to 921,600 bps transmission speed
- 16KV ESD protection

### Diagnostics

- Power LED
- LED to show different software conditions

### Additional Functions

- Battery buffered real time clock (RTC)
- Reset

### **Mass Storage CF**

- Rugged CompactFlash, industrial – grade
- Max. 16 GB supported
- MTBF  $\geq$  1,000,000 hours
- No moving parts
- Shock: 1000 G max.
- Removable flash card
- Bad Block Scanning/Handling
- Static Wear-Leveling System
- 6-Bit ECC
- 2,000,000 write/erase cycles
- Vibration: 15 G peak to peak max.
- Very short access time

### **Mass Storage SATA HDD Raid Level 1 or 0 possible (optional)**

- Two server HDDs, for continuous operation
- Max. 2 TB
- MTBF  $\geq$  1,200,000 hours

### **Mass Storage SATA SSD Raid Level 1 or 0 possible (optional)**

- No moving parts
- Max. 128 GB supported
- Very short access time
- Very high write/read performance

### **Supported Operating Systems**

- Windows XP Professional
- Linux

### **Optical Drive (optional)**

- CD/DVD writer with Slot-in technology

### **Video**

- Standard VGA interface

### **Operating Environment**

- Operating temperature: 0° C to 50° C
- Storage temperature: 0° C to 60° C
- Relative humidity (non condensing): 5 % to 95 %

**General**

- All components are CE certified and tested according to type of test EN 61000-6-2:2005; EN 61000-6-4:2007
- Height: 1 U
- Dimension (W x H x D): 19" x 1.75" x 15"  
(482.6 mm x 44.45 mm x 381 mm)
- Weight: 5.80 kg

**Assembled by IPCOMM GmbH/Germany**

## 5 Appendix

### 5.1 Backup, Restore (only for Industrial PCs with Windows XP Professional OS – IPC191V3WIN)

The operating system Windows XP, the protocol conversion software **ipConv** and the backup software “Acronis True Image” are preinstalled at the IPC191. For saving space on the CompactFlash only necessary components have been installed. The access to the CompactFlash has been minimized by system optimizing.

#### 5.1.1 Restoration / Reinstallation

If the origin state of the system shall be restored the provided CD / DVD created by “Acronis True Image” is necessary.

The CD/DVD was created before delivery and includes Windows XP, Acronis True Image and the **ipConv** software.

The following steps are necessary for the system restoration:

1. So far as possible, backup your configuration data and the software (if these are more current than the delivered one).
2. Insert Acronis True Image Backup CD/DVD in your CD/DVD drive.
3. Please, reboot the system. The System boots from CD/DVD drive and the True Image boot menu appears.
4. Please, select the option „One - Click Restore “.

Please, note that all data on the CompactFlash are erased with this process.

#### 5.1.2 Backup

Backup of software and configuration is described in the “**ipConv** documentation”.

For generating a backup of the entire system (CompactFlash) please use the preinstalled backup software “Acronis True Image”. The image files can be stored on CD, DVD or USB mass storage devices.

Further information of the backup software is described in the attached documentation belonging to the Acronis True Image software.

### 5.2 IPC191V3 CAD Drawing

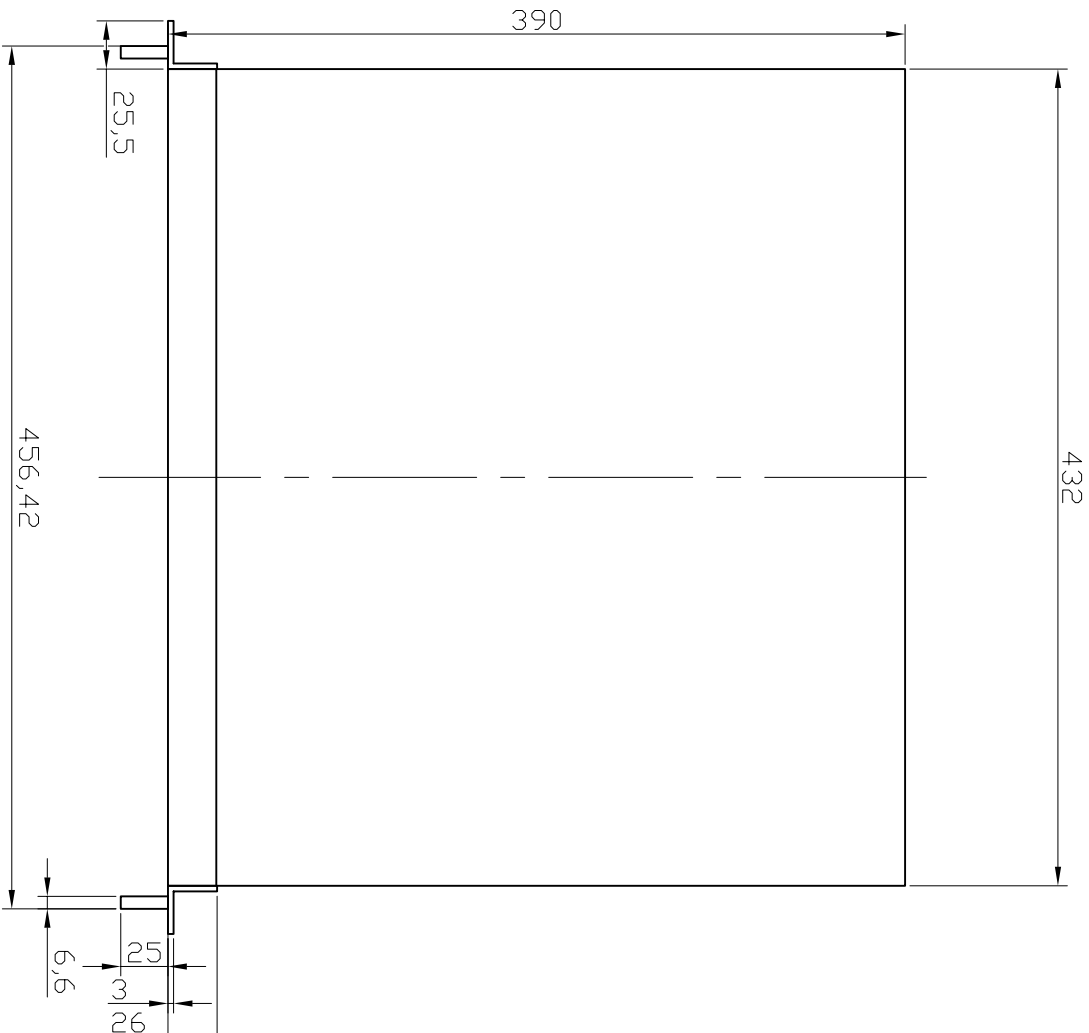
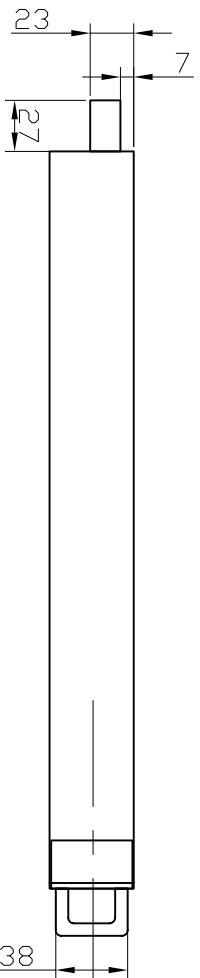
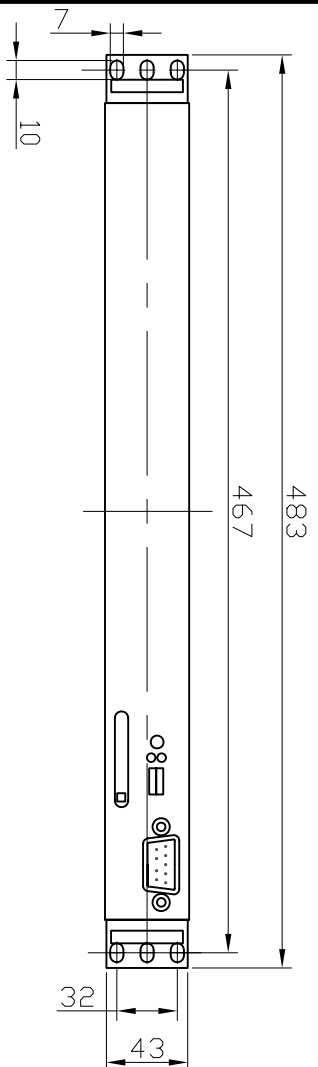

Subject to change without prior notice

Scale: 1 : 4

General tolerance			
Date	Name		
11.05.09	M. Dstapovski		
Checked		IPC191V3 19"	
Standard			
IPCDMM GmbH		V 1.0	Page 1
Origin:		Repl. for:	Replaced through:
			Pg.