

General Operating, Maintenance and Installation Manual

Hardware Platform for Protocol Converter

„Midrange Embedded Controller“

- MEC -

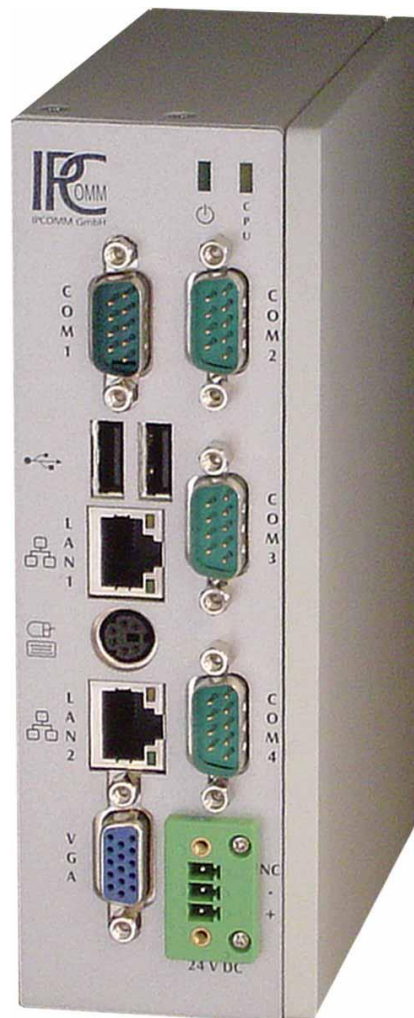

IPCOMM GmbH

Gundstraße 15
91056 Erlangen
Germany

Phone: +49 9131 92076-0
Fax: +49 9131 92076-10
Internet: <http://www.ipcomm.de>
E-Mail: info@ipcomm.de

Edition Dec 2010
Version 1.2



Index

1. INTRODUCTION	2
2. HARDWARE DESCRIPTION	3
2.1 INTRODUCTION OF THE DEVICE	3
2.2 CONTROLS AND DISPLAY ELEMENTS	3
2.3 HARDWARE COMPONENTS.....	4
2.3.1 <i>Mainboard</i>	4
2.3.2 <i>Onboard RS232/422/485 Interfaces</i>	5
2.3.3 <i>Jumper setting of serial interfaces</i>	6
2.3.3.1 COM1 Mode Select for RS-232/422/485: JP5/JP7/JP10.....	6
2.3.3.2 COM1 Mode Select: JP6.....	7
2.3.3.3 COM2 Mode Select: JP8.....	7
2.3.3.4 COM4 Mode Select: JP11.....	7
2.3.3.5 COM3 Mode Select: JP12.....	7
2.3.4 <i>Network Interfaces</i>	7
2.3.5 <i>CompactFlash</i>	8
2.3.6 <i>CMOS Lithium Battery</i>	10
2.3.7 <i>Power Supply</i>	12
2.3.8 <i>Keyboard & Mouse Port</i>	12
3. DIAGNOSTIC	13
4. TECHNICAL DATA	14
5. MEC CAD CHART	16

1. Introduction

All technical information, descriptions and illustrations contained in this operating, maintenance and installation manual remain our property and shall not be used otherwise than for operating this system, nor shall they be copied, reproduced or passed on to third parties or brought to their notice without our prior written consent.

The information represented in this manual is in keeping with current standards and is subject to later alterations.

This manual contains important instructions referring to safe installation, commissioning, operation and maintenance.

Read this manual carefully before starting up the protocol converter and observe the instructions.

In order to comply with the guidelines for electro-magnetic compatibility with this embedded controller only CE-certified components are used in compliance with project-specific requirements.

It is to be noted that the hardware platform (MEC) has not been protected against lightning and the operator should, *if desired*, take appropriate protective precautions.

Finally we want to draw your attention to the fact that any warranties with respect to the embedded PC will be invalid in the event that:

- Operation, servicing and maintenance are not carried out accurately according to the instructions; repairs are not carried out by our personnel or without our prior written consent.
- Commissioning is not carried out by our personnel or we have not given our approval for the commissioning or the commissioning is carried out by untrained personnel.
- The unit is used inadequately, incorrectly, negligently or inappropriately or for a purpose other than that originally intended.
- The serial number is removed from the product.

For your protection, observe the following safety precautions when setting up your equipment:

- Follow all cautions and instructions marked on the equipment.
- Ensure that the voltage and frequency of your power source match the voltage and frequency inscribed on the equipment's electrical rating label.
- Never push objects of any kind through openings in the equipment. Dangerous voltages may be present. Conductive foreign objects could produce a short circuit that could cause fire, electric shock or damage to your equipment.

All trademarks and brand names contained in this user manual are for identification purposes only and can be property of their respective holders.

2. Hardware Description

2.1 Introduction of the device

This embedded PC designed for industrial environment offers a high degree of flexibility, performance and reliability.

In our company, an intensive test execution of any device takes place. Before and after a 48 hour Burn-in-Test each device must run through a complete function test.

All components are cooled passively.

Important for the selection of our components are particularly items like quality, availability and a high durability.

The mains power supply is 24 V DC.

The basic system can be equipped with respective PC/104 or MINI-PCI cards.

2.2 Controls and display elements

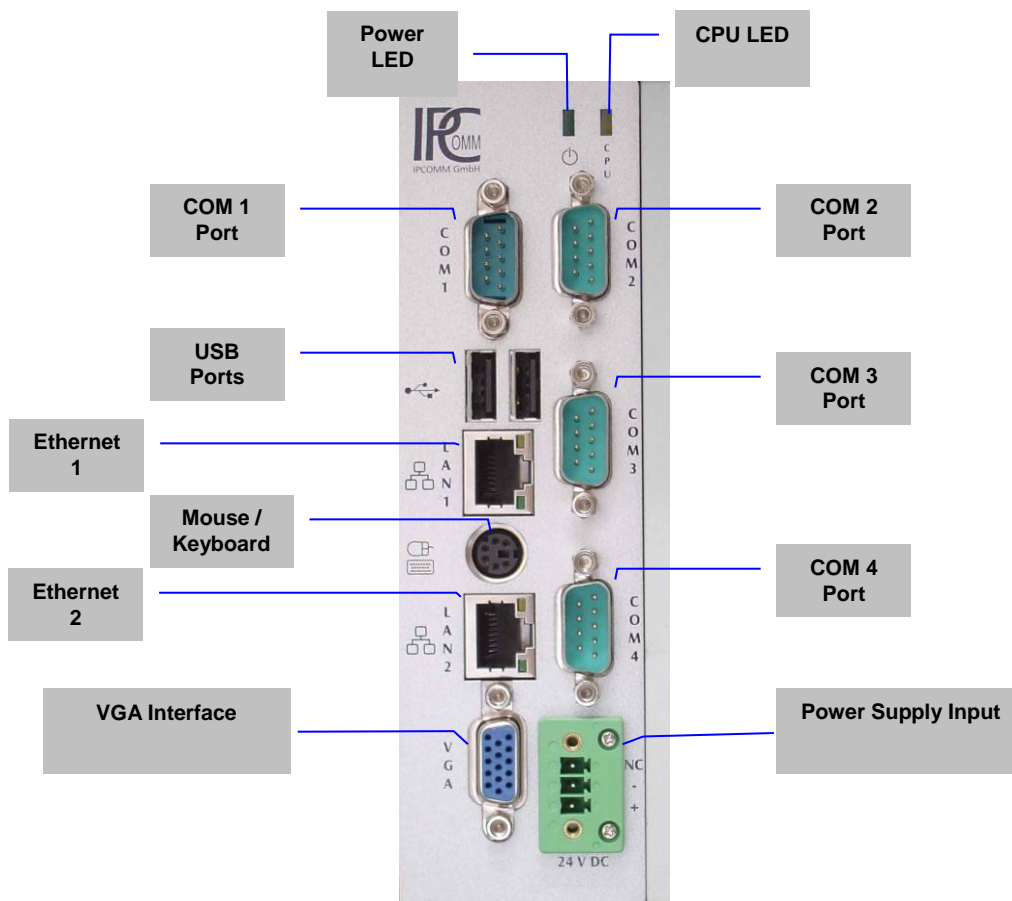

Figure 1: MEC front view

“Figure 2: MEC rear view” shows the rear view of the device. Here is the clip for mounting on a DIN-RAIL placed.

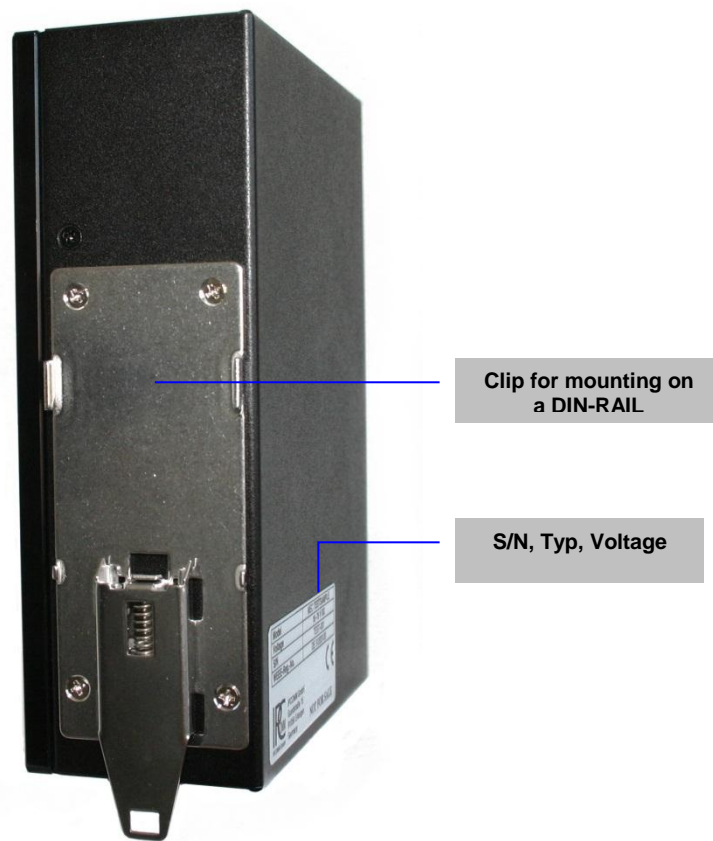

Figure 2: MEC rear view

2.3 Hardware Components

2.3.1 Mainboard

The used mainboard is an ultra-compact x86 platform with two integrated network interfaces and four serial interfaces. The systems heart consists of a passively cooled AMD processor with 500 MHz and supports up to 1 GB system memory.

Available interfaces

- 4 x RS232
- 2 x LAN
- 2 x USB
- VGA
- Keyboard-/Mouse Port

2.3.2 Onboard RS232/422/485 Interfaces

COM 1¹

SERIAL PORT DB9 male connector		Pin	RS232	RS422	RS485
		1 ²	DCD	TX-	DATA-
		2	RXD	TX+	DATA+
		3	TXD	RX+	---
		4	DTR	RX-	---
		5	GND	---	---
		6	DSR	---	---
		7	RTS	---	---
		8	CTS	---	---
		9 ²	RI	GND	GND

Figure 3: Pin-assignment of DB9 9-pin RS232/422/485 interface at MEC (COM 1)

COM 2 - 4

SERIAL PORT DB9 male connector		Pin	RS232
		1 ²	DCD
		2	RXD
		3	TXD
		4	DTR
		5	GND
		6	DSR
		7	RTS
		8	CTS
		9 ²	RI

Figure 4: Pin-assignment of DB9 9-pin RS232 interface at MEC (COM 2- 4)

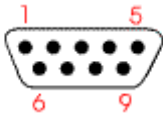
¹ COM1 is jumper selectable as RS-232/422/485. See chapter 2.3.3 / 2.3.3.1.

² All ports feature +5V power capability on DCD and +12V power capability on RI depending on the jumper setting of Pin 1 und Pin 9. See chapter 2.3.3 / 2.3.3.1 - 2.3.3.5.

2.3.3 Jumper setting of serial interfaces

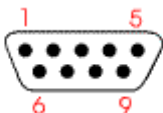
The figure shows the jumper and connector placement onboard the SBC84620 series.

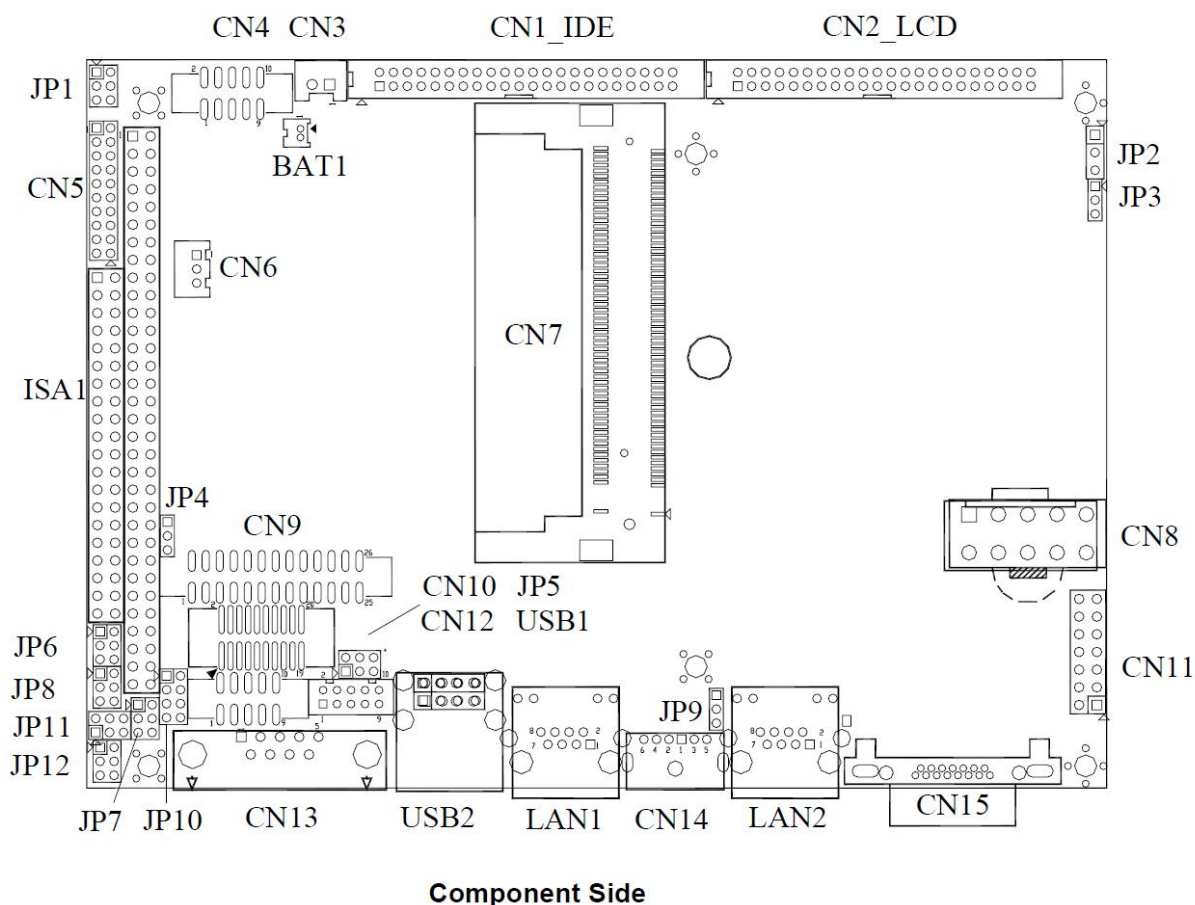
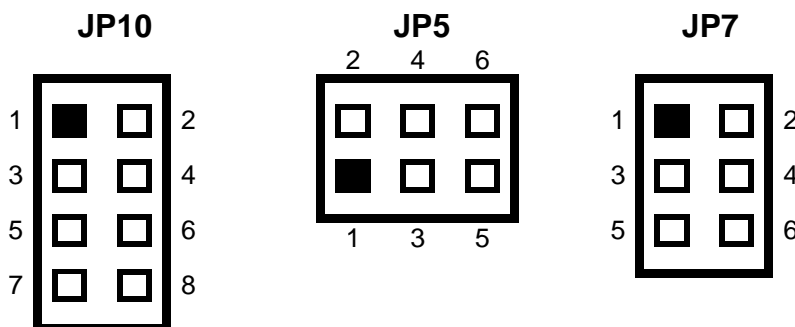

Figure 5: Mainboard placement of the series SBC84620 AMD® Geode GX3 All-in-One Capa Board

2.3.3.1 COM1 Mode Select for RS-232/422/485: JP5/JP7/JP10

COM1	JP10	JP5	JP7
RS-232 (Default)	1-2	3-5, 4-6	3-5, 4-6
RS-422	3-4, 7-8	1-3, 2-4	1-3, 2-4
RS-485	5-6, 7-8	1-3, 2-4	1-3, 2-4



2.3.3.2 COM1 Mode Select: JP6

COM1	JP6
*Pin 1=DCD	Short 3-5(Default)
*Pin 1=5V	Short 1-3
*Pin 9=RI	Short 4-6(Default)
*Pin 9=+12V	Short 2-4

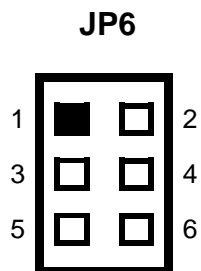

2.3.3.3 COM2 Mode Select: JP8

COM2	JP8
*Pin 1=DCD	Short 3-5(Default)
*Pin 1=5V	Short 1-3
*Pin 9=RI	Short 4-6(Default)
*Pin 9=+12V	Short 2-4

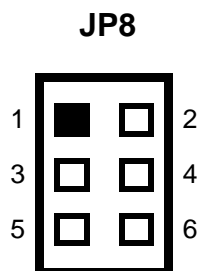

2.3.3.4 COM4 Mode Select: JP11

COM4	JP11
*Pin 1=DCD	Short 3-5(Default)
*Pin 1=5V	Short 1-3
*Pin 9=RI	Short 4-6(Default)
*Pin 9=+12V	Short 2-4

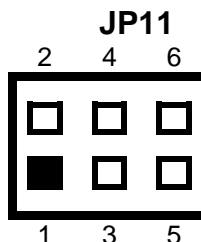

2.3.3.5 COM3 Mode Select: JP12

COM3	JP12
*Pin 1=DCD	Short 3-5(Default)
*Pin 1=5V	Short 1-3
*Pin 9=RI	Short 4-6(Default)
*Pin 9=+12V	Short 2-4

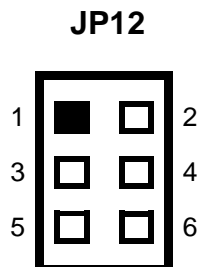

2.3.4 Network Interfaces

The embedded PC has two 10/100 Mbps BaseT (RJ45) interfaces.

2.3.5 CompactFlash

The CompactFlash card serves as a mass storage device, i.e. for storing the operating system, the applications and configuration data.

The advantage over a hard drive is the elimination of rotating parts. Thus the reliability can be much increased. The CompactFlash has an MTBF of at least 4.000.000 hours.

The CompactFlash adapter is simply connected to the IDE bus of the CPU module and treated just like a hard disk.

In case it is required to change the CompactFlash, do the following:

CAUTION! The change of a CompactFlash or a battery requires ESD safety measures to avoid charge transfer to conductor plate and system components. Please do this only on an earthed and conductive surface when using an antistatic wrist strap.

1. Disconnect the embedded controller from mains; disconnect data lines.
2. Remove the device from DIN-RAIL.
3. Unscrew the housing by loosening the corresponding five screws (A) (see figure below). It is recommended to use a PH2 screwdriver.

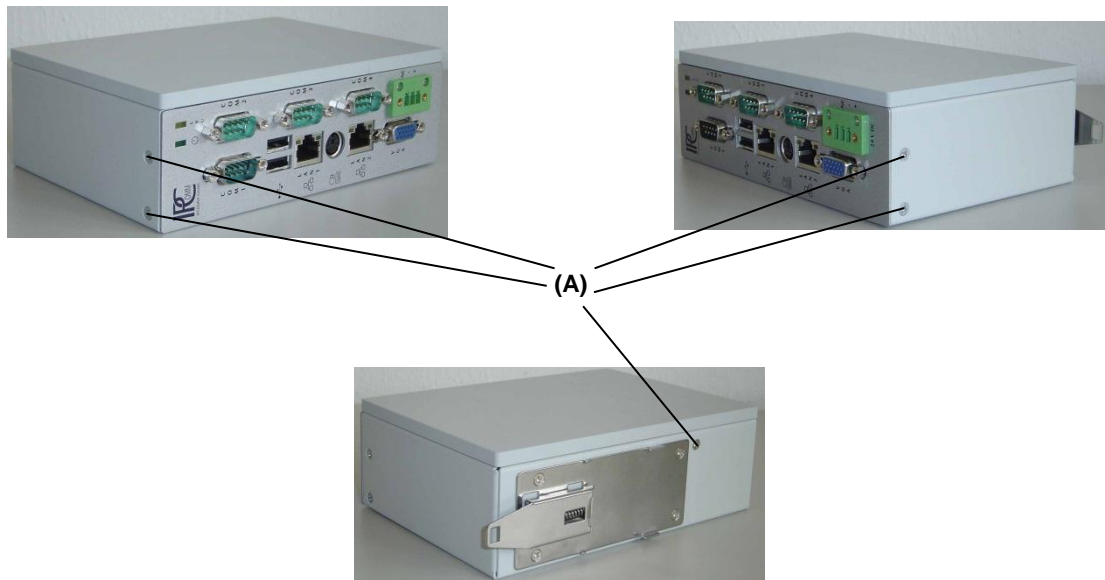

Figure 6: Loosening screws (A)

4. After loosening all screws, take off the plug-in board (B) from the housing (C) according to the direction shown in the figure below. The front board connected with the plug-in board via the cable set, is pulled out by that.

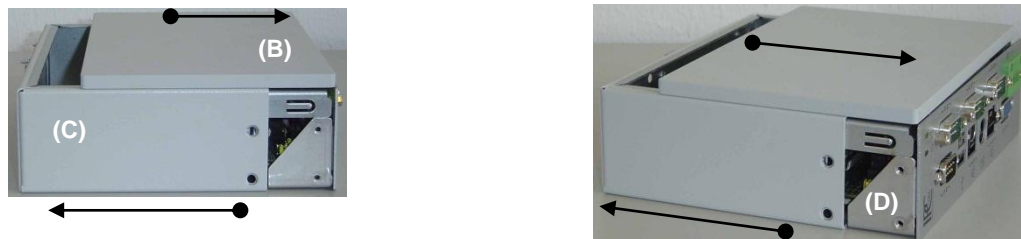

Figure 7: Demounting of the housing cover

- Now, after “Figure 6: Loosening screws (A)” and “Figure 7: Demounting of the housing cover” change the CompactFlash.
Insert the new CompactFlash true sided into the CompactFlash-holder (please note the different groove width) until it snaps in beyond the pressure point.

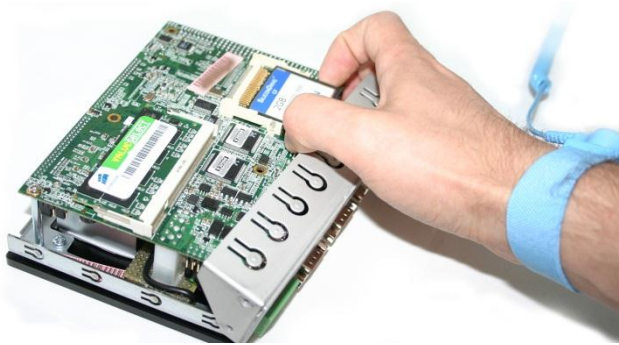

Figure 8: Change of CompactFlash

- Insert in correct position the plug-in board (conductor plate unit) incl. cooling element together with the front board into the housing. Insert and tight the previously loosened screws (“Figure 6: Loosening screws (A)” and “Figure 9: Assembling”).



Figure 9: Assembling

- Start again the DIN-Rail embedded controller after installation according to these rules.

2.3.6 CMOS Lithium Battery

The on-board CMOS RAM stores system configuration data and has an on-board battery power supply. The long-life Lithium battery has normally a lifetime of at least 5 years.

If the CMOS battery is empty and the CMOS information deleted, the CMOS-RAM is programmed by the BIOS with default settings.

The converter works faultlessly even if the battery does not provide the CMOS RAM. Synchronizing (NTP) date and time is necessary after battery change. In case the protocol converter is time synchronized, the system has date and time available without battery as well.

Only a qualified electronics technician should perform the battery replacement. However, there is the possibility to engage IPCOMM GmbH with that. Incorrect replacement might cause the danger of explosion. Replace the battery exclusively by the same type. Used batteries are to be disposed absolutely in accordance with the manufacturer's instructions. Contact IPCOMM GmbH to order a low priced spare battery.

First, carry out the steps described in chapter 2.3.5, 1. - 4. to change the battery.

CAUTION: The device must be zero potential. The change of a battery requires ESD safety measures to avoid charge transfer to conductor plate and system components. Please do this only on an earthed and conductive surface when using an antistatic wrist strap.

5. After demounting the housing cover, unfix the six screws identified in the figure below to loosen the mainboard. Fold the front board forward carefully. It is recommended to use a PH2 screwdriver.

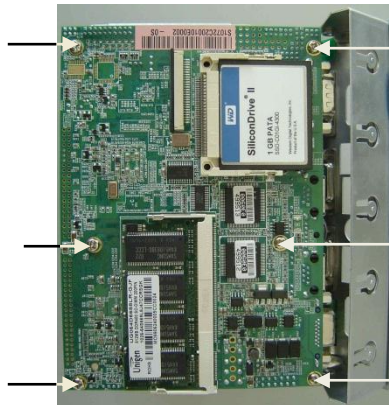

Figure 10: The mainboard is fixed to the housing by 6 screws

6. Carefully lift the mainboard because it is still wired with the connectors. We recommend not loosening the cabling. Some connections are additionally secured. There is also the danger of reassembling in error.

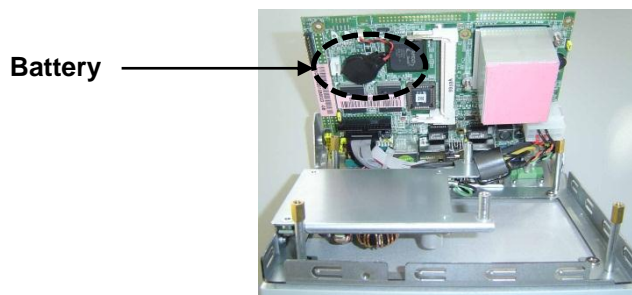

Figure 11: Battery placement

7. The battery is attached to the mainboard with a double-sided adhesive tape. Carefully take off and unplug the battery. Remove the foil of the adhesive tape of the spare battery; stick the battery in section (E) and insert the plug.

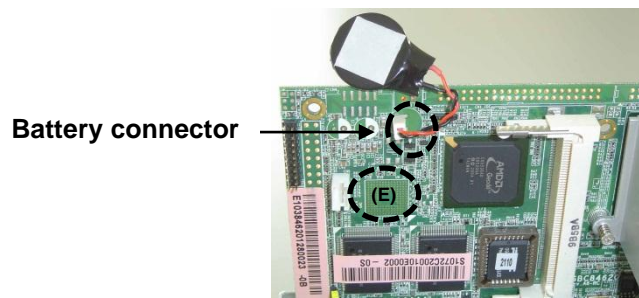

Figure 12: Battery attachment

8. Now, place the mainboard accurately onto the housing. Mind the positions of the screw joints. Connect the mainboard with the housing by fixing the six screws again.

The final assembling is described in chapter 2.3.5, step 6.

2.3.7 Power Supply

MEC operates with different power supplies. Please pay attention to the correct polarity and input voltage.

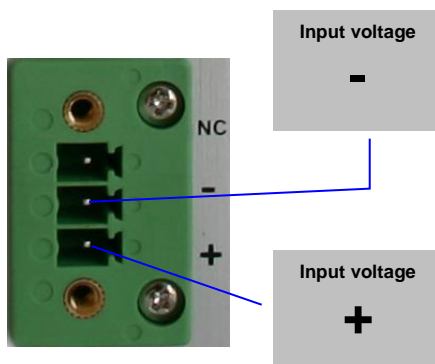

Figure 13: Power supply connection

The device is always equipped with a connector. Please, use this connector exclusively. The connection to the voltages source must be poled correctly. The wire cross section must be at least 0,75 mm².



Figure 14: Connector for power supply

2.3.8 Keyboard & Mouse Port

MEC has a PS2 keyboard and mouse port available. To use this port take the enclosed Y-cable.

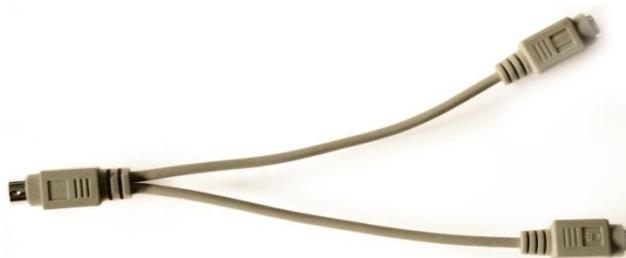

Figure 15: PS2 Y-cable for keyboard and mouse

3. Diagnostic

The CPU-LED visualizes the status of the operating system and the converter software. The following figure shows the possible operating states.

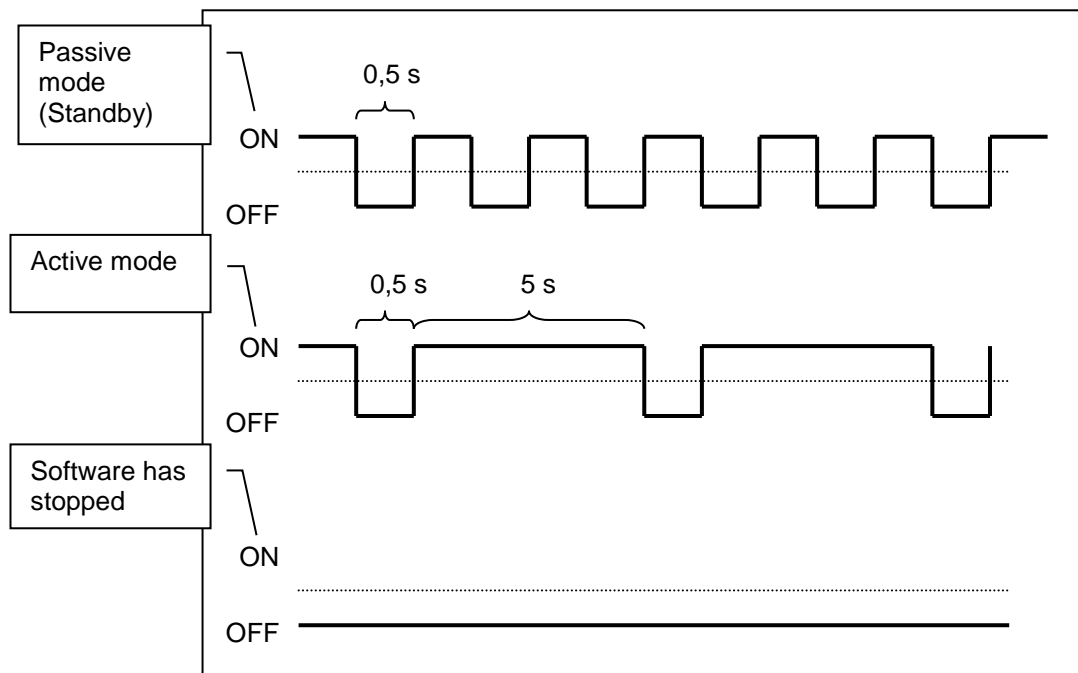

Figure 16: CPU LED display

4. Technical Data

General

- No rotating parts

Processor

- AMD LX800 500 MHz processor, fanless

Dynamic Memory

- DDR RAM, max. 1024 MByte, SO-DIMM

System I/O Outlet

- 1 x 9-pin D-SUB male for RS232/422/485
- 3 x 9-pin D-SUB male for RS232
- 1 x Compact Flash socket
- 1 x PS/2 mouse and keyboard interface
- 2 x LAN RJ-45 for 10/100Base-T
- 2 x USB
- 1 x 15-pin D-SUB female for VGA

Diagnostic LEDs

- Power
- Software state (CPU-LED)
- Link and activity for LAN interfaces

Mass storage

- Rugged CompactFlash, industrial – grade
- Removable flash card
- No moving parts
- Max. 8 GB storage capacity supported
- Shock: 1000 G max.
- MTBF >4.000.000 hours
- Bad Block Scanning/Handling
- Static Wear-Leveling System
- 6-Bit ECC
- 2.000.000 write/erase cycles

Additional Functions

- Battery buffered real time clock (RTC)
- Watchdog

Power consumption

- 24 V DC / 9 W max. ³

Standards

- CE

Housing

- Aluminum and steel chassis, including clip for mounting on a 35 mm DIN-Rail
- Protection class: IP50

Dimensions (without clip)

- 50x160x111mm (W/H/D)

Weight

- 1 kg

Operating Environment

- Operating /storage temperature: -10°C – 50°C / -10°C - 70°C
- Relative humidity: 5 % to 90 % non-condensing

³ Voltage and power data depend on the used type.

Note: Differences to the delivered type are possible.

5. MEC CAD chart

