

General Operating, Maintenance and Installation Manual

Hardware Platform for Protocol Converter

„Small Embedded Controller“

- SEC2 -



IPCOMM GmbH

Gundstraße 15
91056 Erlangen
Germany

Telephone

+49 9131 92076-0

Fax:

+49 9131 92076-10

Internet:

<http://www.ipcomm.de>

E-mail:

info@ipcomm.de

Edition September 2010
Version 1.2



DIN EN ISO 9001:2008
Zertifikat: 01 100 040757

Index

1. INTRODUCTION	2
2. HARDWARE DESCRIPTION	3
2.1 GENERAL.....	3
2.2 OPERATING AND DISPLAY ELEMENTS ON THE DEVICE FRONT PANEL	3
2.3 HARDWARE COMPONENTS.....	6
2.3.1 <i>Onboard RS232 Interfaces</i>	6
2.3.2 <i>Ethernet Interfaces</i>	7
2.3.3 <i>Onboard Serial Console Port</i>	7
2.3.4 <i>Power Supply</i>	8
2.3.5 <i>CPU LED</i>	9
3. TECHNICAL DATA	10

1. Introduction

All technical information, descriptions and illustrations contained in this operating, maintenance and installation manual remain our property and shall not be used otherwise than for operating this system, nor shall they be copied, reproduced or passed on to third parties or brought to their notice without our prior written consent.

The information represented in this manual is in keeping with current standards and is subject to later alterations.

This manual contains important instructions referring to safe installation, commissioning, operation and maintenance.

Read this manual carefully before starting up the protocol converter and observe the instructions.

In order to comply with the guidelines for electro-magnetic compatibility in industrial PCs (or other variants) only CE-certified components are used in compliance with project-specific requirements.

It is to be noted that the protocol converter (SEC2) has not been protected against lightning and the operator should, *if desired*, take appropriate protective precautions.

All trademarks and brand names contained in this user manual are for identification purposes only and can be owned by their respective holders.

Finally, we want to draw your attention to the fact that any warranties with respect to delivered goods will be invalid in the event that:

- Operation, servicing and maintenance are not carried out accurately according to the instructions; repairs are not carried out by our personnel or without our prior written consent.
- Commissioning is not carried out by our personnel or we have not given our approval for the commissioning or the commissioning is carried out by untrained personnel.
- The unit is used inadequately, incorrectly, negligently or inappropriately or for a purpose other than that originally intended.
- The serial number is removed from the product.

For your protection, observe the following safety precautions when setting up your equipment:

- Follow all cautions and instructions marked on the equipment.
- Ensure that the voltage and frequency of your power source match the voltage and frequency inscribed on the equipment's electrical rating label.
- Never push objects of any kind through openings in the equipment. Dangerous voltages may be present. Conductive foreign objects could produce a short circuit that could cause fire, electric shock, or damage to your equipment.

2. Hardware Description

2.1 General

As hardware platform for the protocol converter the “Small Embedded Controller” – SEC2 is used. This maintenance free solution offers a maximum usability, reliability and optimal price-performance ratio.

Intensive tests of the embedded controller are done in our company.
Before and after a 48 hour burn-in test each device must run through a complete function test.

All components are cooled passively.

The mains power supply is 9 - 48 V DC.

2.2 Operating and Display Elements on the Device Front Panel

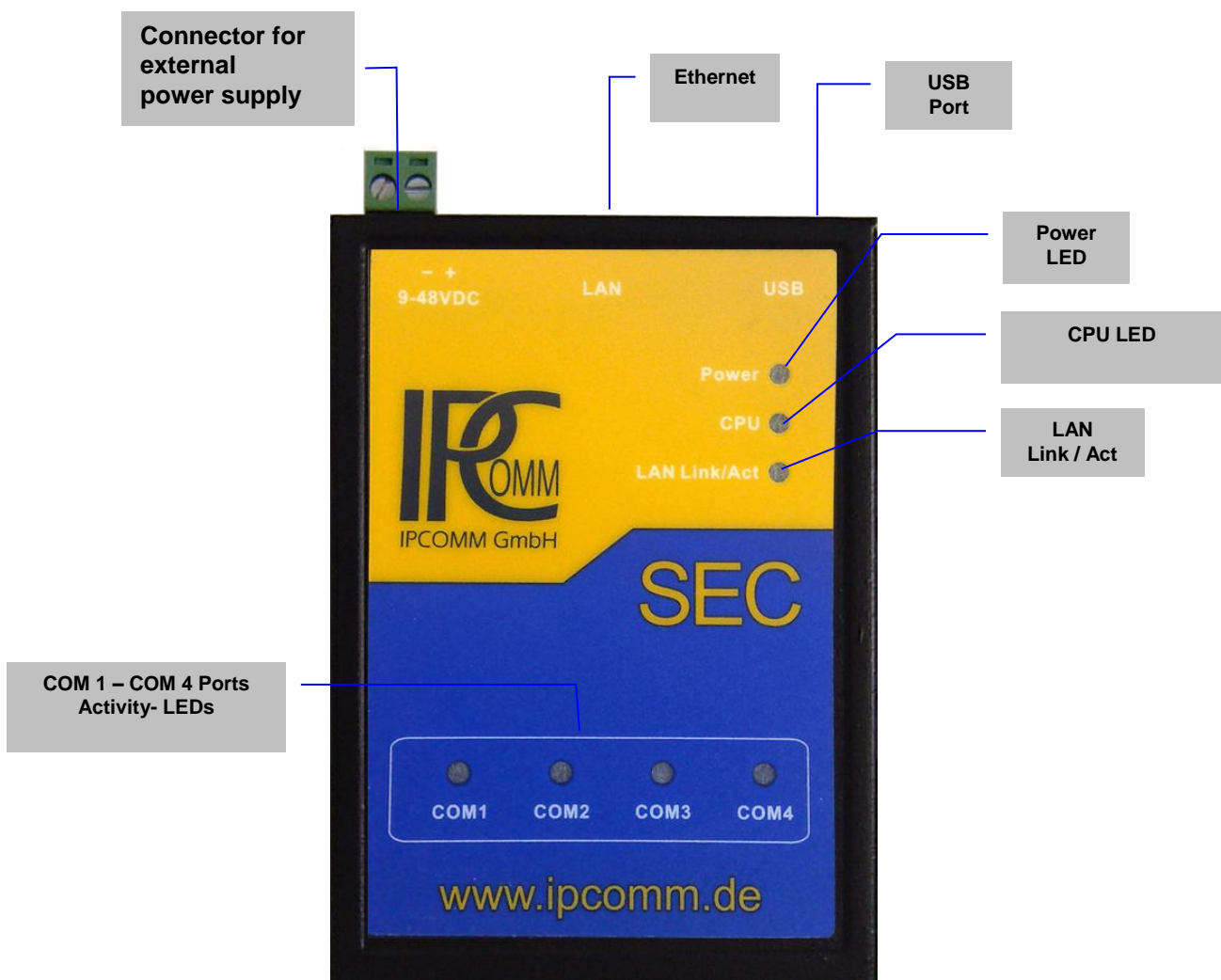

Figure 1: SEC2 front view

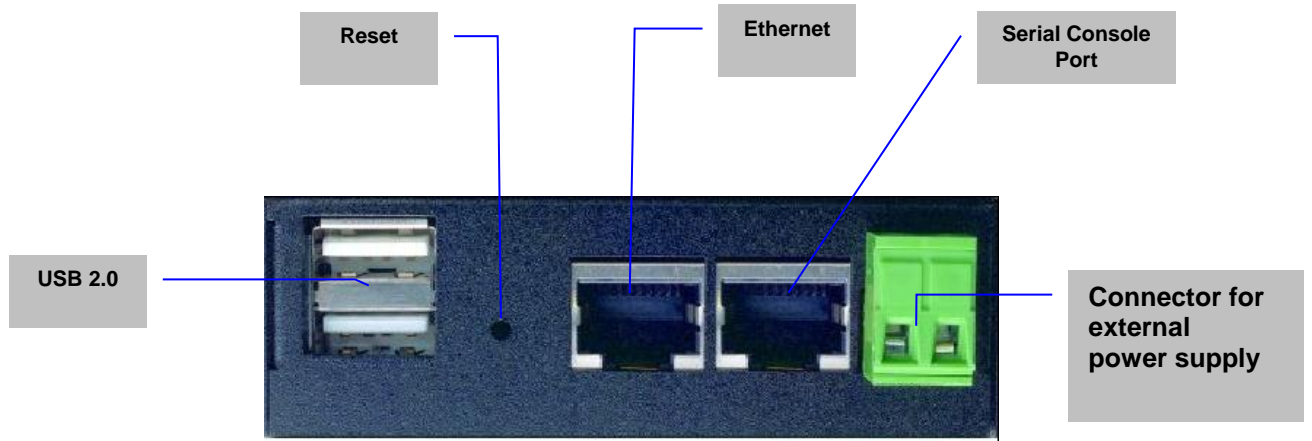

Figure 2: *SEC2 left side view*

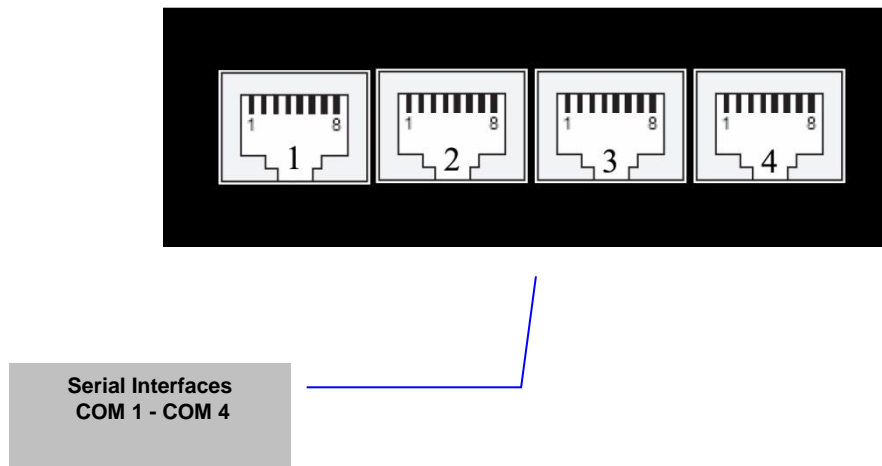

Figure 3: *SEC2 right side view*

Figure 4 shows the rear view of the device. There is the clip for mounting on a DIN-Rail.

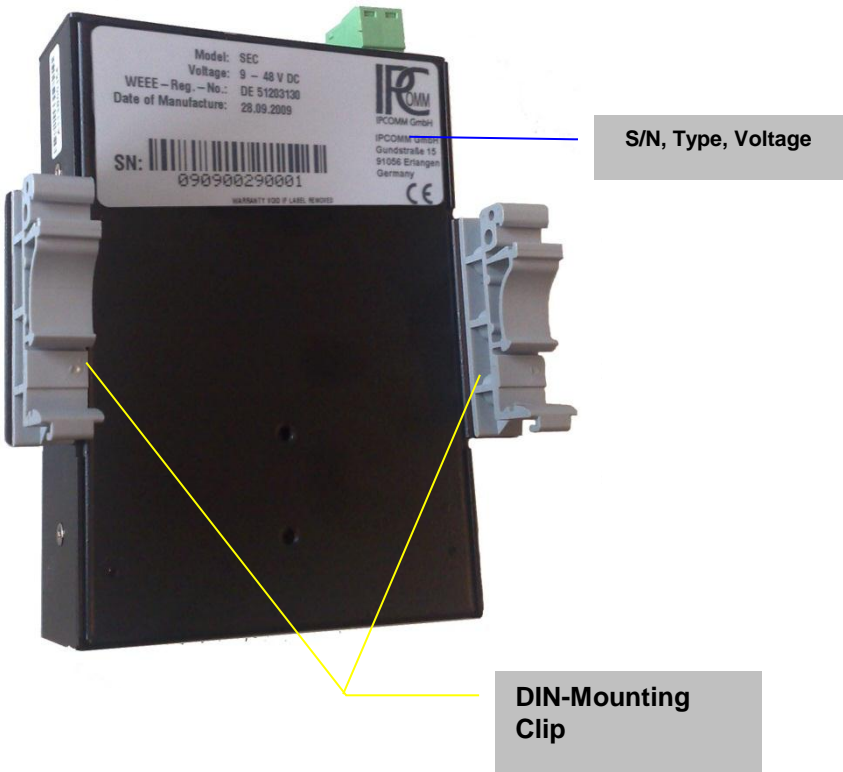

Figure 4: SEC2 rear view

2.3 Hardware Components

2.3.1 Onboard RS232 Interfaces

The serial interfaces have an RJ45 connector available. COM 1 is software configurable as RS232/RS422/RS485, COM 2 to COM 4 can be used as RS232/RS485. See the pin assignment below.

Attention! COM1 and COM2 – COM4 have a different pin assignment!

SERIAL PORT RJ45 female connector		Pin	RS232	RS422	RS485
		1	DSR	---	---
		2	RTS	TXD+	Data+
		3	GND	GND	GND
		4	TXR	TXD-	Data-
		5	RXD	RXD+	---
		6	DCD	RXD-	---
		7	CTS	---	---
		8	DTR	---	---

Figure 5: Pin assignment of RJ45 interface (COM 1)

SERIAL PORT RJ45 female connector		Pin	RS232	RS422	RS485
		1	---	---	---
		2	RTS	---	Data+
		3	GND	---	GND
		4	TXR	---	Data-
		5	RXD	---	---
		6	---	---	---
		7	CTS	---	---
		8	---	---	---

Figure 6: Pin assignment of RJ45 interfaces (COM 2 – COM 4)

2.3.2 Ethernet Interfaces

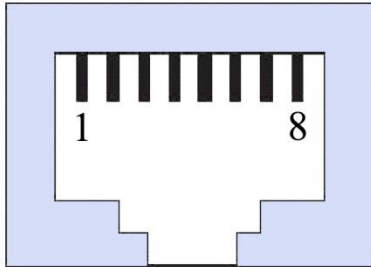
The embedded controller features one 10/100 Mbps BaseT (RJ45) Ethernet interface.

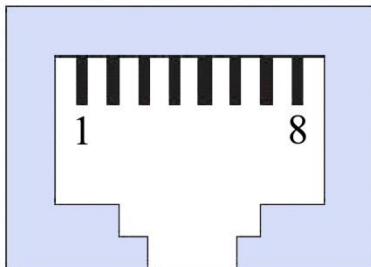
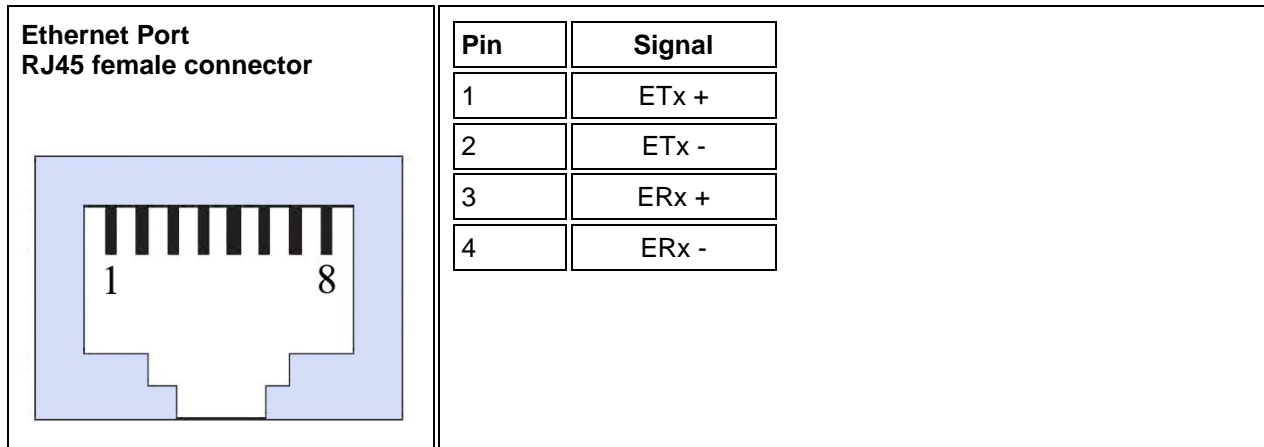

Figure 7: Pin assignment of Ethernet RJ45 interface

2.3.3 Onboard Serial Console Port

The serial console port is used for locally accessing SEC2 by RS232 port. The console port uses the RJ45 connector and is next to Ethernet port. **Therefore, please be careful to plug in the right connector!**

In addition to the serial console signal, the console RJ45 port also provides GPIO (programmable I/O signal) function. The GPIO port is CMOS I/O and programmable as digital input or output. Power up setting is digital input mode with 75K ohm pull up resistor.

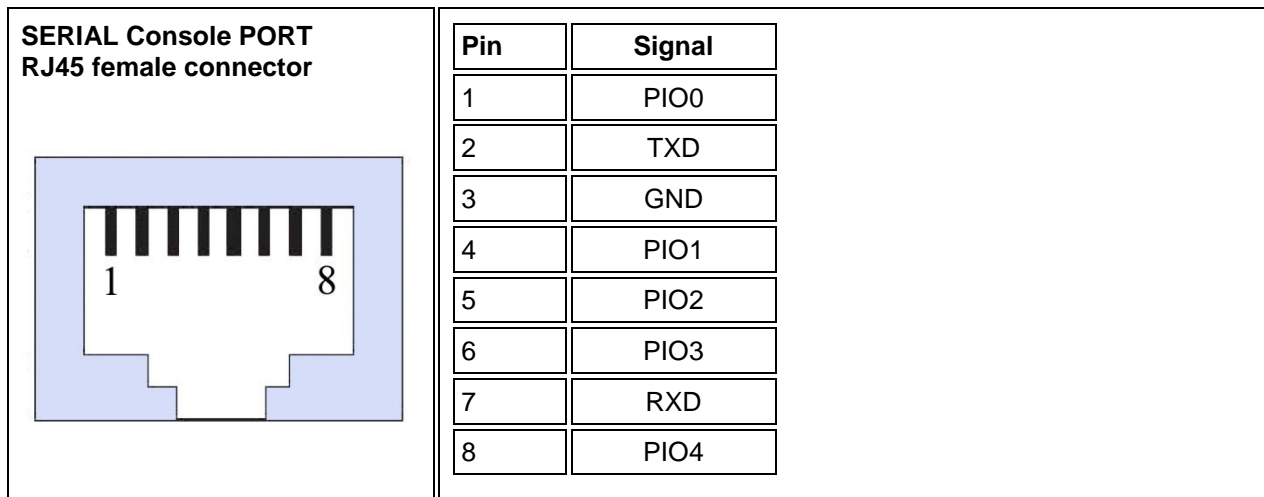

Figure 8: Pin assignment of RJ45 interface of serial console port

2.3.4 Power Supply

The main power supply of SEC2 is 9 - 48 V DC. Please pay attention to the correct polarity and input voltage.



Figure 9: *Power supply input*

The female connector is always supplied. This connector has to be used. By connecting the cable with the connector, the correct polarity must be kept. The wire cross-section must be at least 0.5 mm².



Figure 10: *Female connector for external power supply*

2.3.5 CPU LED

The CPU LED shows the states of conversion software and operating system.

Following figure shows all possible indications:

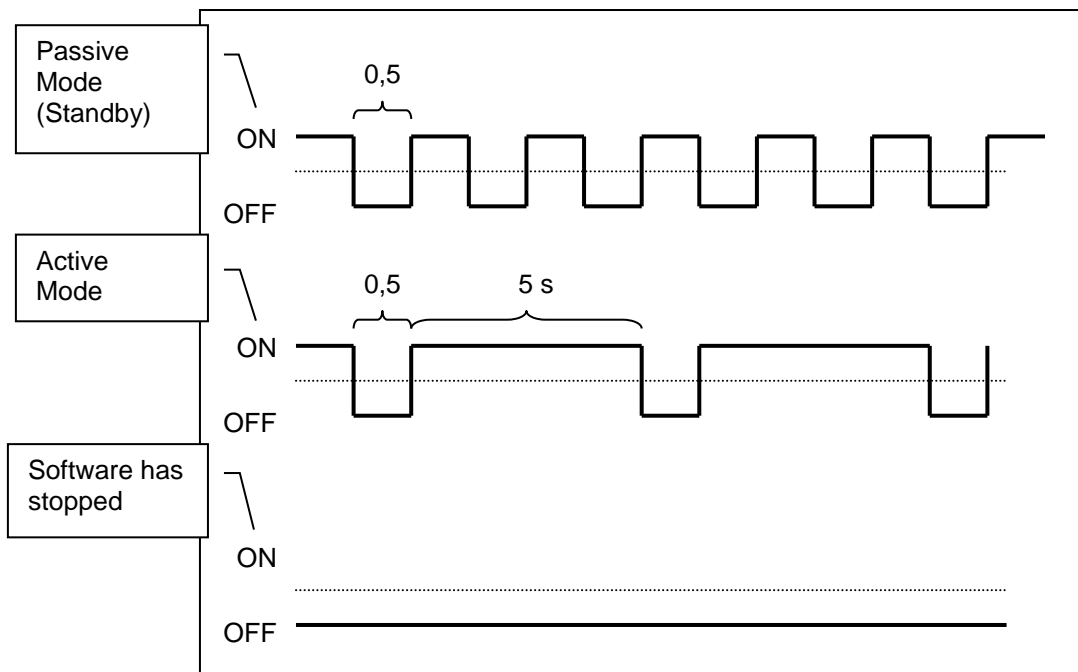

Figure 11: CPU-LED indications

3. Technical Data

General

- No rotating parts

Processor

- 400 MHz CPU

Dynamic Memory

- 128 MB SDRAM

Network Interface

- 1 x RJ-45 for 10/100 Base-T
- Protection: 1.5 KV magnetic isolation

Serial Ports

- 1 x RJ45 for RS232/422/485
- 3 x RJ45 for RS232 / RS485 (without DTR, DCD und DSR signal)
- Baud rate: up to 921.6 Kbps
- Parity: None, Even, Odd, Mark, Space
- Data Bits: 5, 6, 7, 8
- Stop Bit: 1, 1.5, 2 bits
- Flow Control: RTS/CTS, XON/XOFF, None
- RS-485 direction control: auto, by hardware

USB Ports

- 2 x USB 2.0 compliant, supports low speed (1.5Mbps) and full-speed (12 Mbps) data rate

Diagnostic LEDs

- Power
- Software state (CPU-LED)
- Link and activity of LAN interface
- Transmit and receive LEDs for the RS232 interfaces

Mass Storage

- 128 MB Flash

Additional Functions

- Battery buffered real time clock (RTC)
- Watchdog
- Reset
- GPIO
- Serial console port

Power Input / Power consumption

- 9 - 48 V DC / 4 W max.

Standards

- CE Class A, FCC Class A

Housing

- Steel chassis, including clip for mounting on a 35 mm DIN-Rail

Dimensions (without clip)

- 78 x 108 x 24 mm (W/H/D)

Weight

- 0,4 kg

Operating Environment

- Operating / storage temperature: 0°C – 70°C / - 20°C - 80°C
- Relative humidity: 5 % to 95 % non-condensing

Note: Differences to the delivered type are possible.