

Channel Switch CS

General Operating, Maintenance and Installation Manual

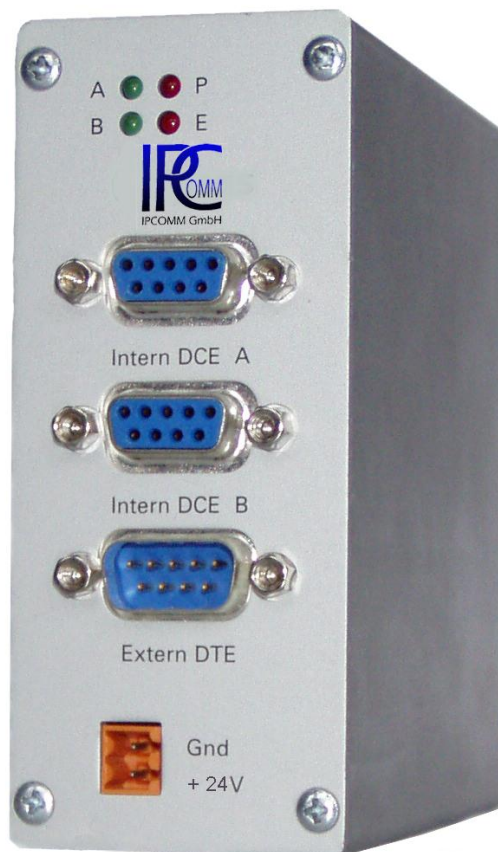

IPCOMM GmbH

Gundstraße 15
D-91056 Erlangen

Phone: +49 9131 92076-0

Fax: +49 9131 92076-10

Internet: <http://www.ipcomm.de>

Email: info@ipcomm.de

Edition September 2012
Version 2.2



DIN EN ISO 9001:2008
Zertifikat: 01 100 040757

Index

1	INTRODUCTION	2
2	GENERAL SPECIFICATION	3
2.1	APPLICATION.....	3
2.2	NOMENCLATURE.....	4
2.3	OPERATION.....	5
2.4	MOUNTING AND DISMOUNTING	6
2.5	ELECTRICAL INSTALLATION	7
2.5.1	<i>Circuit Diagram</i>	7
2.5.2	<i>Pin Allocation</i>	8
2.6	ELECTRICAL COMMISSIONING.....	9
2.7	MAINTENANCE.....	10
2.8	JUMPER SETTINGS	11
2.9	SCOPE OF DELIVERY	12
3	APPENDIX A – TECHNICAL DATA SHEET	13
4	APPENDIX B – DECLARATION OF EEC COMPLIANCE.....	16

1 Introduction

All technical information, specifications and illustrations contained in this Operating, Maintenance and Installation Manual remain our property and shall not be used otherwise than for operating this product, nor shall they be copied, reproduced or passed on to third parties or brought to their notice without our prior written consent.

The information represented in this manual is in keeping with current standards and is subject to later alterations.

This manual contains important instructions referring to safe installation, commissioning, operation and maintenance.

Read this manual carefully before starting up the Channel Switch and observe the instructions.

Although a surge test has been successfully completed (up to 0.5 kV) the operator should, if necessary, implement appropriate protection measures against the possible impact of lightning.

Caution!

The Channel Switch is a class A device. This device can cause radio disturbances in residential buildings. In this case the operator might be obliged to carry out appropriate measures and take responsibility.

All trademarks and brand names contained in this user manual are for identification purposes only and can be owned by their respective holders.

Finally we want to draw your attention to the fact that any warranties with respect to the delivered goods will be invalid in the event that:

- Operation, servicing and maintenance are not carried out accurately according to the instructions, repairs are not carried out by our personnel or without our prior written consent.
- Commissioning is not carried out by our personnel or we have not given our approval for the commissioning or the commissioning is carried out by untrained personnel.
- The unit is used inadequately, incorrectly, negligently or inappropriately or for a purpose other than that originally intended.
- The serial number is removed from the product.

2 General Specification

2.1 Application

The Channel Switch is used for switching data and control signals in control direction in a redundant system. Figure 2.1 shows how the Channel Switch is embedded into the system. It has been designed for switching the communication channels via an RS232 interface in redundant Protocol Converter systems.

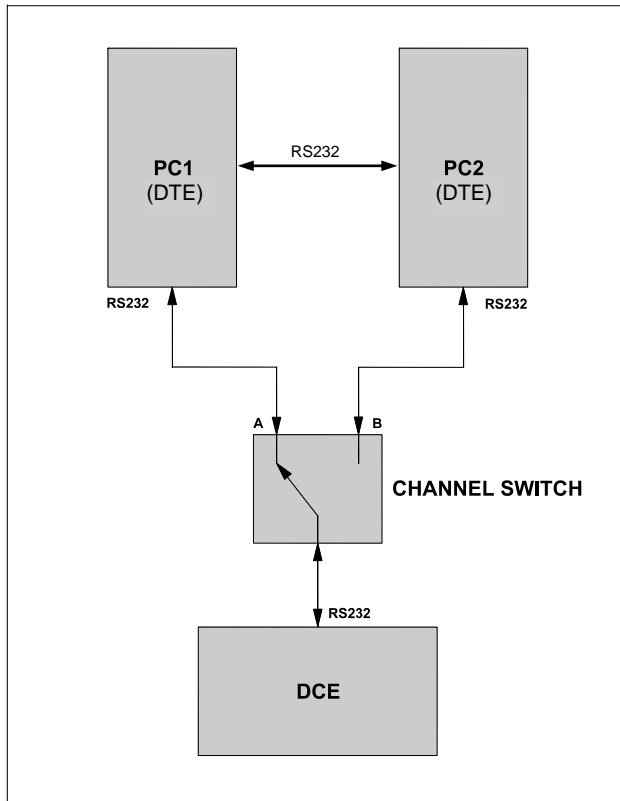

The Channel Switch is connected to two Protocol Converters, PC1 and PC2 (DTE – Data Terminal Equipment) and a Data Communication Equipment (DCE). The links between the devices are established via RS232 interfaces. In the system shown opposite the Protocol Converter PC1 is the active one, i.e. it communicates with the Data Communication Equipment, while the other Protocol Converter PC2 remains passive.

Fig. 2.1: Channel Switch in a redundant system

If the first Protocol Converter fails or needs to be switched off for maintenance during operation the second Protocol Converter resumes communication automatically. It sends a switchover command of a defined pulse string to the Channel Switch. If the Channel Switch recognizes this pulse string as valid, the Channel Switch relays the data and control signals from the second Protocol Converter to the Data Communication Equipment. The connection to the first Protocol Converter is shut off. Only the data and control signals in control direction, those are TX, DTR and RTS signals, are redirected.

A bistable relay control inside the Channel Switch enables to preserve the former switch position, even if the operating voltage is turned off. Only a defined series of pulses can activate the switch.

2.2 Nomenclature

The circuitry of the Channel Switch is housed in a robust aluminium casing. The ports for connecting to the Protocol Converters and the Data Communication Equipment as well as four LEDs for displaying the operating state of the Channel Switch are located on the front panel. On the back you will find the clip for mounting on a 35 mm DIN rail. The respective position of the parts mentioned is shown in figure 2.2.

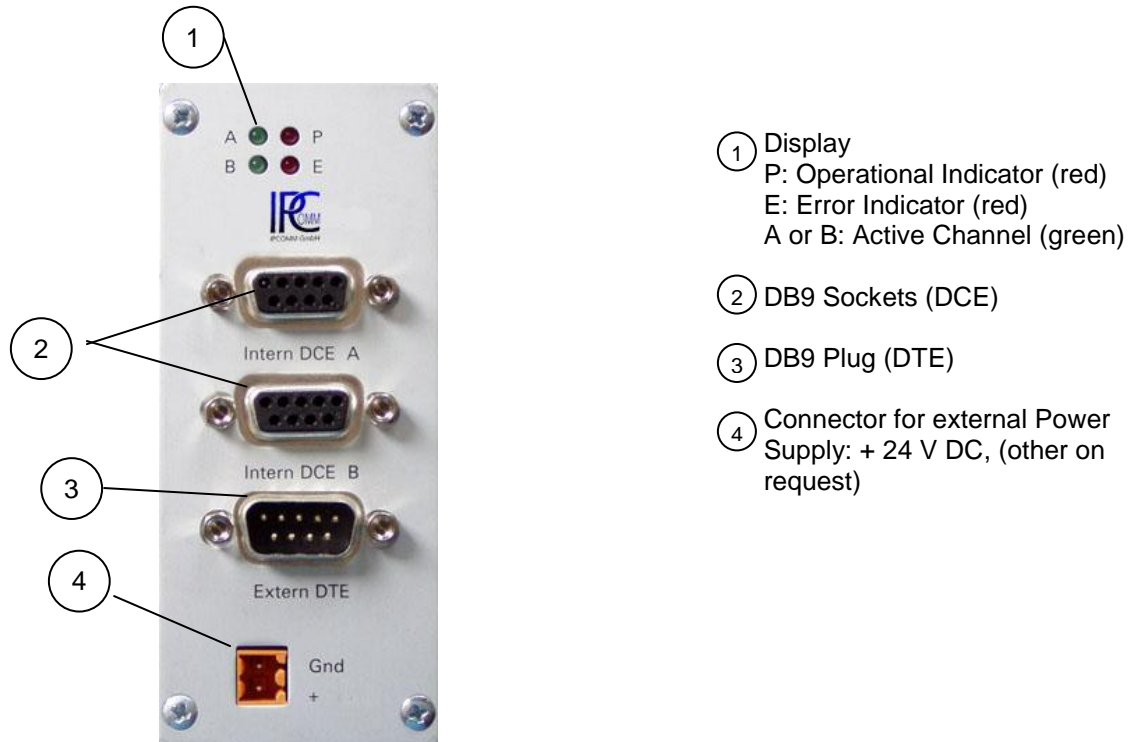

Fig. 2.2: Nomenclature

2.3 Operation

The Channel Switch (protection class IP 40) has been designed for installation in a switch cabinet and is supplied with 24 V DC via an external power supply. In order to maintain operating function, greater variations in temperature should be avoided. We recommend an air-conditioned operating environment for the Channel Switch.

Possible sources of interference, such as current inverters and power current lines near the Channel Switch should be avoided.

In order to ensure problem-free operation the following conditions have to be observed:

- Temperature Range: 0° C – 55° C
- Relative Humidity: 5 % - 95 % **non-condensing**
- Installation as per IP 40, i.e. installation site and environment comply with the appropriate degree of protection.
The housing is not protected against the penetration of water!
- The supply voltage must remain within the permissible voltage range (see technical data sheet)
- Mounting on electro-conductive and grounded DIN mounting rail.

Note: Excessive voltages either fed directly via the power voltage or indirectly via data and control lines, mains power lines or as a result of voltage excesses to the Channel Switch might cause damage to the Channel Switch.
Possible interferences of this kind must be avoided.

Important: Provided that a power supply is delivered by IPCOMM GmbH, the required instructions can be found in the enclosed operating manual.

2.4 Mounting and Dismounting

Since there is a clip on the back panel of the housing no tools or additional material are required for mounting the Channel Switch on the DIN rail.

Figure 2.4.1 opposite shows how the Channel Switch is mounted on DIN rail C.

By pressing in the direction of marked point B clip A snaps into place on the DIN rail. The casing is grounded via the DIN rail. It must therefore be ensured that the DIN rail is electro-conductive and grounded.

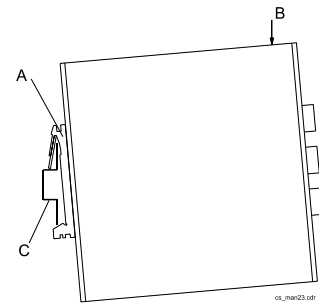

Fig. 2.4.1: Mounting the CS

For dismounting push the casing in the direction of marked point D while pulling at the bottom side of the casing towards point E (see figure 2.4.2).

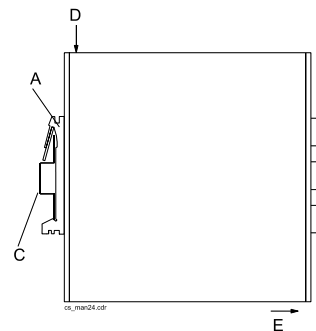

Fig. 2.4.2: Dismounting the CS

2.5 Electrical Installation

2.5.1 Circuit Diagram

The Channel Switch is connected to the Protocol Converters and the Data Communication Equipment as shown by the following circuit diagram, fig. 2.5.1.

The operating voltage of the Channel Switch is + 24 V DC \pm 10 %, optional 12 V DC \pm 10 %.

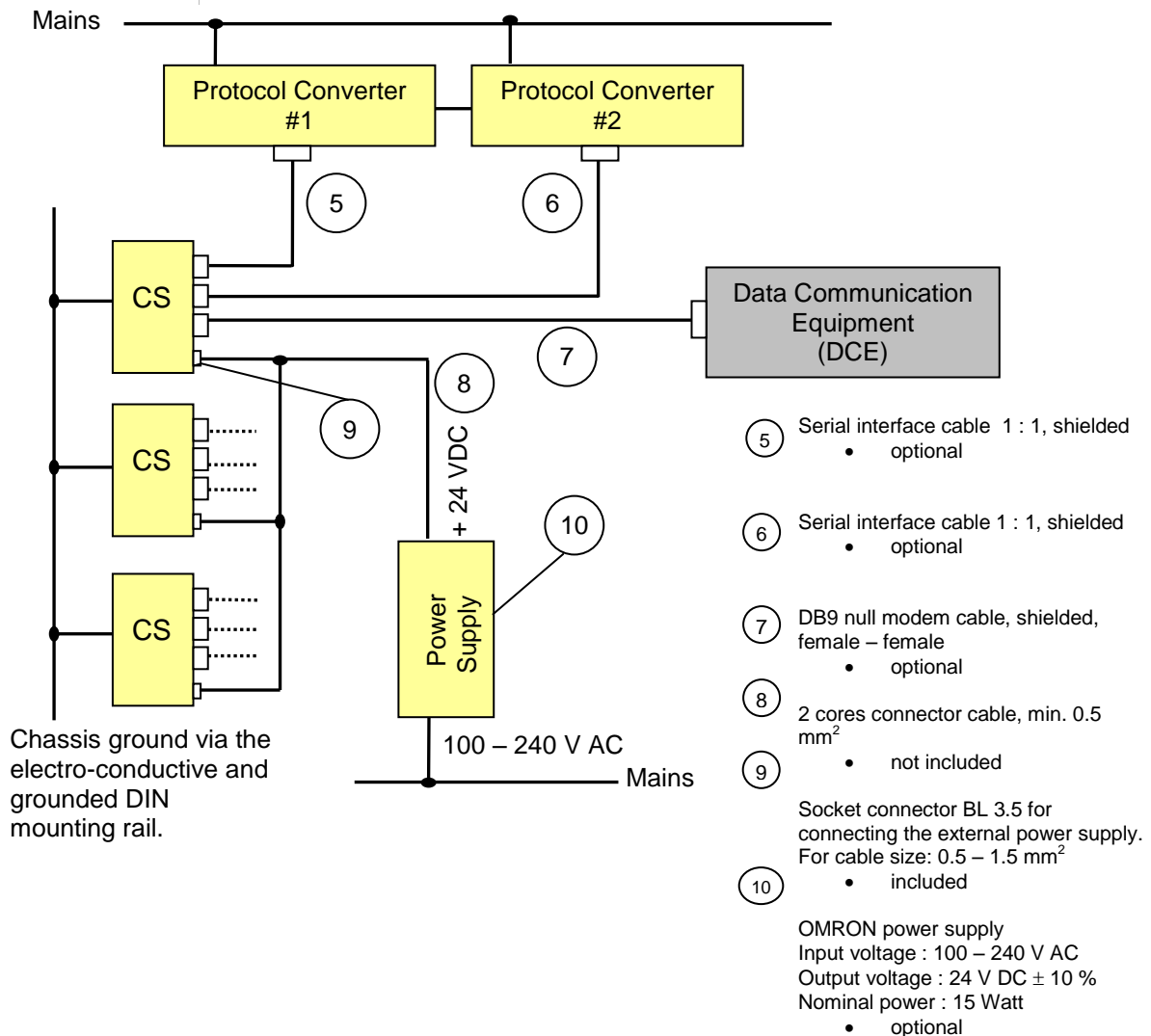

Fig. 2.5.1: Electrical Installation

The power input of a Channel Switch is approx. 0.5 Watt.

The maximum number of Channel Switches to be connected in parallel circuit is therefore limited by the maximum rating of the power supply.

Important: In order to comply with regulations on electromagnetic compatibility, keep data lines and the 24 V power supply cord of the Channel Switch as short as possible.

2.5.2 Pin Allocation

Figure 2.5.2 shows the pin allocation for the Channel Switch. The pins marked with an * are required for communication.



Abb. 2.5.2 Pin allocation for the Channel Switch

RTS: Request To Send
CTS: Clear To Send
DTR: Data Terminal Ready
Rx: Receive Data
Tx: Transmit Data
SGnd: Signal Ground
DSR: Data Set Ready
RI: Ring Indicator
CD: Carrier Detect

2.6 Electrical Commissioning

After completing the electrical installation of the Channel Switch as shown in circuit diagram 3.5.1 electrical commissioning can begin.

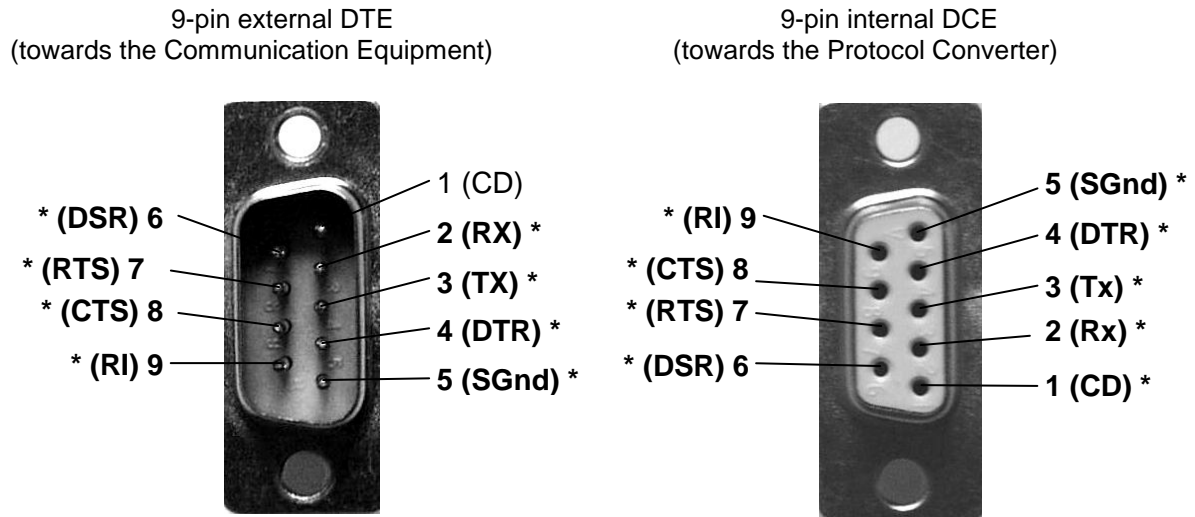
Immediately after starting up the power unit, the Channel Switch executes an internal initialization sequence. The red LED (P) indicates that the operating voltage is on. In addition the current switch position of the bistable relay inside the Channel Switch and the currently active channel are identified. This is indicated by the green LED (A) or (B). LED (A) indicates that channel A is connected to the Data Communication Equipment. Correspondingly LED (B) shows that channel B is connected to the Data Communication Equipment.

The initialization procedure takes about 55 ms. Subsequently you can start communication between the active Protocol Converter and the Data Communication Equipment.

If LED (E) lights up shortly an error has occurred. In this case the Channel Switch initializes automatically. Such an error could be caused by a temporary malfunction of the serial interfaces.

2.7 Maintenance

Generally the Channel Switch is maintenance-free.

Fig.2.7.2 shows the assembled circuit board of the Channel Switch. The centerpiece of the circuit board is the μ -Controller.



Fig. 2.7.1: Channel Switch, open

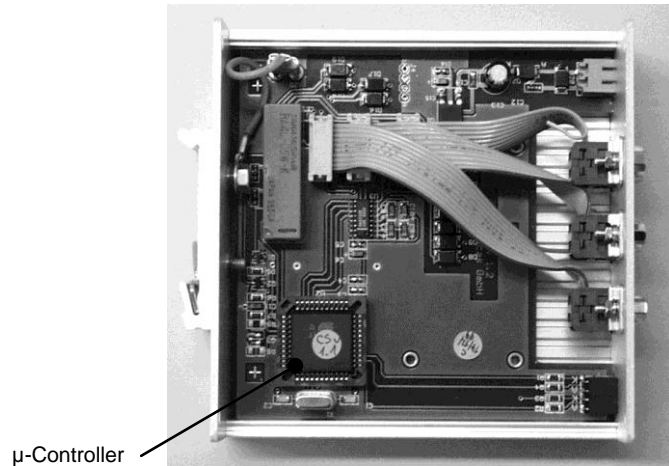

Fig. 2.7.2: Circuit Board Channel Switch

Should it become necessary to replace the μ -Controller, proceed as follows:

1. Disconnect the Channel Switch from the mains, detach the data lines.
2. After dismantling as per point 2.4, remove the side panel of the housing as shown in fig. 2.7.1 by loosening the 4 screws.
3. The μ -Controller is removed from the PLCC socket by means of the PLCC pliers. Apply the pliers in such a way that the parts marked with an A correspond to those of the socket (see fig. 2.7.2, 2.7.3 and 2.7.4).
4. When inserting the new μ -Controller ensure that the slanting edge of the μ -Controller corresponds to that of the socket.
Important: Any transfer of charges to the μ -Controller must be avoided.
5. Carefully push the μ -Controller into the socket.
Then replace both side panels of the casing.
Tighten the 4 housing screws.
6. After proper mounting the Channel Switch can be put into operation again.

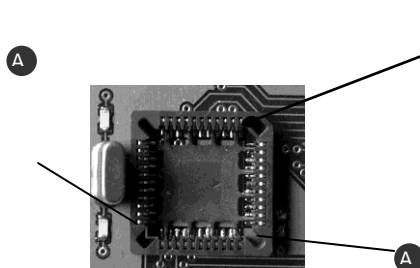

Fig. 2.7.4: Socket for μ -Controller

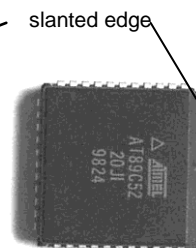

Fig. 2.7.5: μ -Controller

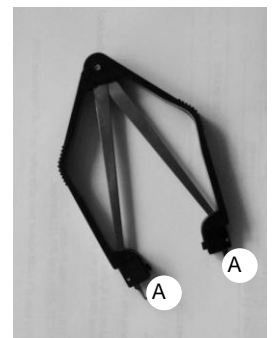
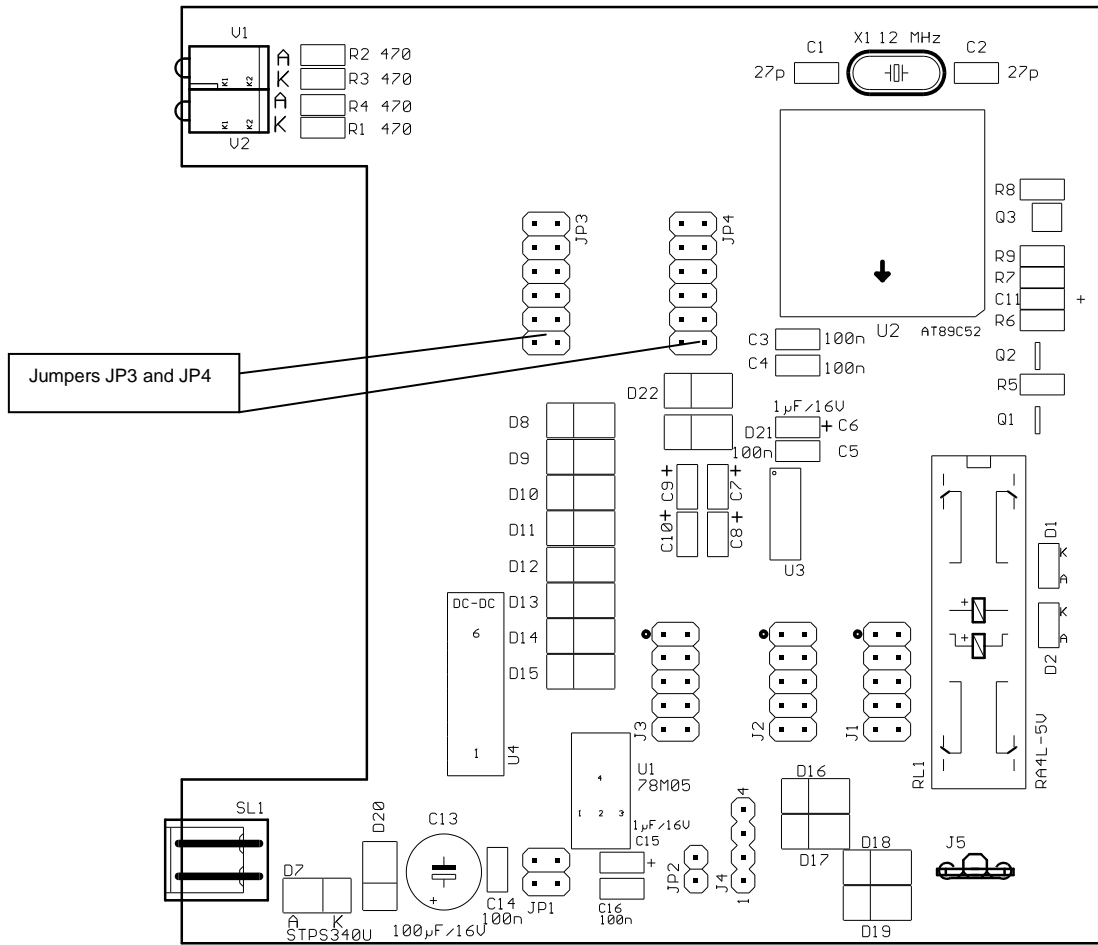

Fig. 2.7.3: PLCC pliers

2.8 Jumper Settings



Case	JP3						JP4					
	1-2	3-4	5-6	7-8	9-10	11-12	1-2	3-4	5-6	7-8	9-10	11-12
1			J	J	J	J	J	J				
2	J	J			J	J			J	J		
3	J	J	J	J							J	J

J = Jumper in
Blank = no Jumper

Case 1 = State of active channel identified by Carrier Detect (Pin 1)
Case 2 = State of active channel identified by Data Set Ready (Pin 6)
Case 3 = State of active channel identified by Ring Indicator (Pin 9)

2.9 Scope of Delivery

- Channel Switch (CS)
- Socket connector 3,5 mm

Optional:

- OMRON power unit for the external power supply of the Channel Switch
100V-240 V AC / 24 V DC, 15 W

3 Appendix A – Technical Data Sheet

Technical Data Sheet

Interfaces

- RS232 (V.24)
- 9 pin SUB-D Socket (connects to DCE)
- 9 pin SUB-D Plug (connects to DTE)
- Baudrate up to 38400 Baud
- CD or DSR or RI for indicating the active channel to the protocol converters

Function Display

- 4 LEDs

Switchover Time

- 140 ms (measured after last valid pulse)

Power Supply

- 24V DC $\pm 10\%$ external, optional 12 V DC $\pm 10\%$

Power Input

- approx. 0,5 W

Protection Requirement

- IP 40

Norms

- CE-certified

Housing

- Aluminium, surface passivated, with clip for mounting on 35 mm DIN rail

Dimensions (without clip fastener)

- Width: 44 mm
- Height: 105 mm
- Depth: 104 mm

Operating Environment

- Operating temperature / storage temperature: 0° C to 55° C / - 10° C to 70° C
- Relative humidity: 5 % to 95 % (non-condensing)

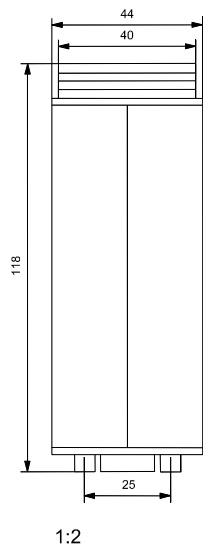
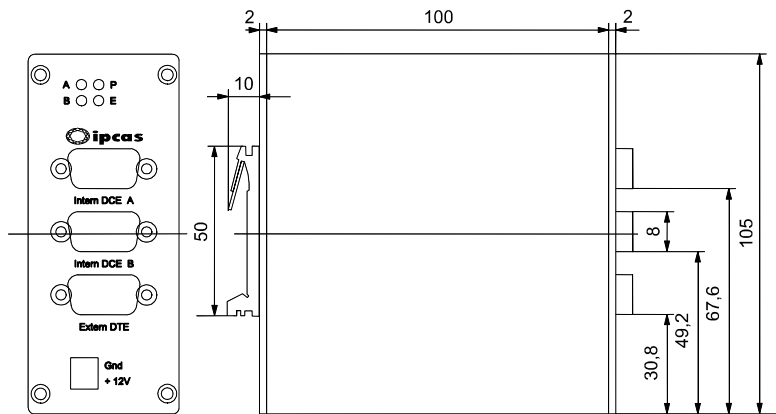

CHANNEL SWITCH	
Title: cs_man26	
Document Number:	REV: 1.0
Date: 24.06.99	1/1

4 Appendix B – Declaration of EEC Compliance

Declaration of EEC Compliance

For the following product

Channel Switch (CS)

it is hereby confirmed that it complies with the main specifications laid down in the Council Guidelines on Harmonizing the Statutory Regulations of the Member States for Electromagnetic Compatibility (89/336/EWG).

Any changes to the Channel Switch not authorized by IPCOMM GmbH invalidate this declaration. The evaluation of this product for electromagnetic compatibility was carried out in accordance with the following standards:

EN 55022/1998
EN 50082-2/1996

Place/Date/Manufacturer's Signature: Erlangen, 15 March 2004

Position of Signatory: Managing Director, Artur Votteler

