

Industrial PC IPC191V4 (Linux OS)

General Operating-, Maintenance- and Installation Manual

Hardware Platform Gateway



IPCOMM GmbH

Walter-Bouhon-Straße 4

90427 Nuremberg

Germany

Phone: +49 911 18 07 91-0

Fax: +49 911 18 07 91-10

Internet: <https://www.ipcomm.de>

Email: info@ipcomm.de

**Edition Oct 2021
Version 1.4**



Table of Contents

1	Introduction	2
2	Hardware Description	3
2.1	General	3
2.2	Hardware Components.....	4
2.2.1	Mainboard.....	4
2.2.2	Onboard RS-232 Interfaces.....	5
2.2.3	8/16 Port RS-232 Serial Interface (RS-232 Interface for Remote Communication).....	5
2.2.4	Ethernet Interfaces	6
2.2.5	CFast Memory Card	6
2.2.6	CMOS Lithium Battery	7
2.2.7	CPU LED	7
2.2.8	Power Supply.....	7
2.2.8.1	AC Power Supply.....	8
2.2.8.2	DC Power Supply	8
3	Overview of Variants / Interface Configuration.....	9
3.1	Variant A	9
3.2	Variant B	10
3.3	Variant E8	11
3.4	Variant E4M	12
3.5	Variant L	12
3.6	Variant PSM.....	13
3.7	Variant PMM.....	13
4	Technical Data.....	14
5	Nomenclature of the IPC191V4 article number.....	16
6	IPC191 CAD Drawing.....	17

1 Introduction

All technical information, descriptions and illustrations contained in this 'Operating, Maintenance and Installation Manual' remain our property and shall not be used otherwise than for operating this system, nor shall they be copied, reproduced or passed on to third parties or brought to their notice without our prior written consent.

The information represented in this manual is in keeping with current standards and is subject to later alterations.

This manual contains important instructions referring to safe installation, commissioning, operation and maintenance.

Read this manual carefully before starting up the gateway and observe the instructions.

In order to comply with the guidelines for electro-magnetic compatibility in industrial PCs (or other variants) only CE-certified components are used in compliance with project-specific requirements.

It is to be noted that the gateway (IPC191V4) has not been protected against lightning and the operator should, if desired, take appropriate protective precautions.

Our RS-232 isolator provides efficient protection of your data and equipment against external influences. We will be pleased to draw up a non-binding offer for you.

Finally we want to draw your attention to the fact that any warranties with respect to the industrial PC will be invalid in the event that:

- Operation, servicing and maintenance are not carried out accurately according to the instructions; repairs are not carried out by our personnel or without our prior written consent.
- Commissioning is not carried out by our personnel or we have not given our approval for the commissioning or the commissioning is carried out by untrained personnel.
- The unit is used inadequately, incorrectly, negligently or inappropriately or for a purpose other than that originally intended.
- The serial number is removed from the product.

For your protection, observe the following safety precautions when setting up your equipment:

- Follow all cautions and instructions marked on the equipment.
- Ensure that the voltage and frequency of your power source match the voltage and frequency inscribed on the equipment's electrical rating label.
- Never push objects of any kind through openings in the equipment. Dangerous voltages may be present. Conductive foreign objects could produce a short circuit that could cause fire, electric shock, or damage to your equipment.
- The industrial PC must be mounted on an equipment carrier (1U) in a 19" rack. A free floating or unilateral mounting may cause defects.
- It is imperative to ensure a consequent strain relief to avoid damage to the connector of the '8 port DB9-male connector cable'.

All trademarks or brand marks mentioned in this document are used for identification purposes only and are property of their respective owners.

2 Hardware Description

2.1 General

As hardware platform for the protocol converter a 19" industrial PC is used. This solution offers a high degree of flexibility, performance and reliability.

Mounting and intensive tests of the industrial PC are done in our company. Each device runs through an intensive function test. This function test includes a burn-in test with full communication of all interfaces (min. 48 hours). Drops of communication, transmission errors and every important component with regard to function, temperature, voltages etc. are monitored.

Hundreds of restarts are executed whereby a connection to all interfaces is established at each reboot.

Quality assurance is done according to the four-eye principle. Each device passes a number of quality inspections.

All components are cooled passively. Only if critical system temperatures have been reached two independent housing fans are switched on automatically. Important for the selection of our components are particular items like quality, availability and a high durability.

The IPC191V4 captivates with its significantly higher processor performance compared to the previous model. It is equipped with 4 CPU cores and up to 8 GB RAM and offers many more interfaces (serial/LAN).

The industrial PC consists of a 19" chassis (1U) with two PCIe extension slots for inserting the appropriate cards.

The mains power supply are 90 – 264 V AC, 104 – 373 V DC auto range, optional 9 – 32 V DC power supply (other on request). The basic system can be equipped as requested with corresponding PCIe plug-in cards.

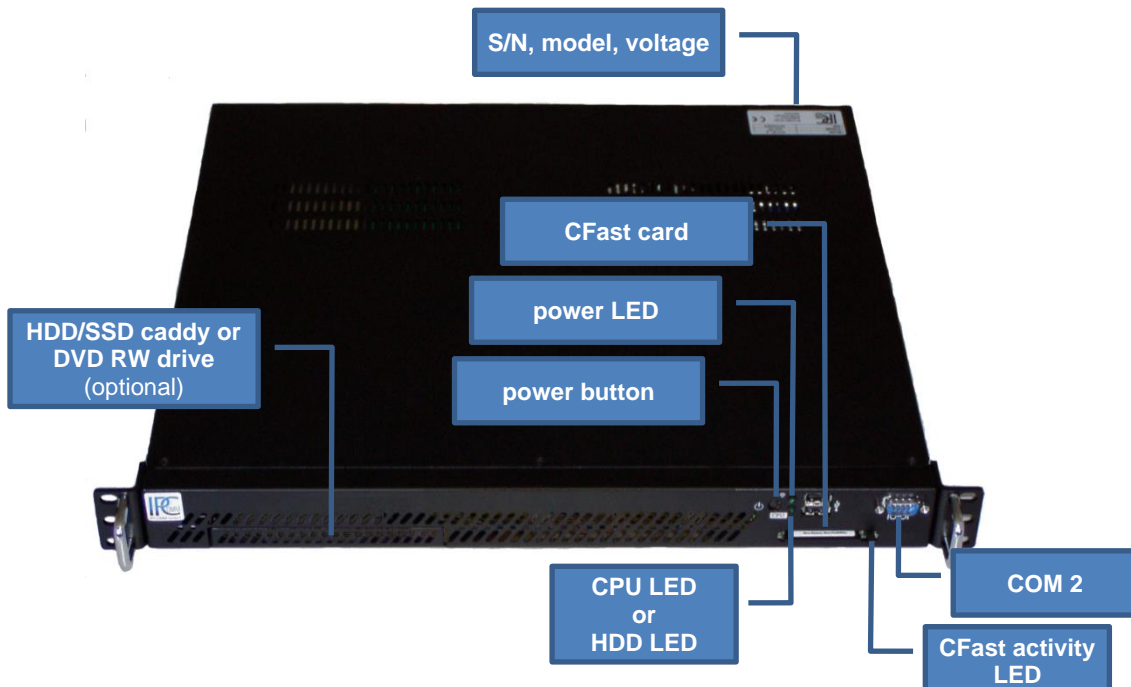

Figure 1: IPC191V4 front view

Figure 2 shows the reverse side of the device. The pin assignments vary according to execution. An overview of the different models can be found in chapter 3 "Overview of Variants / Interface Configuration".

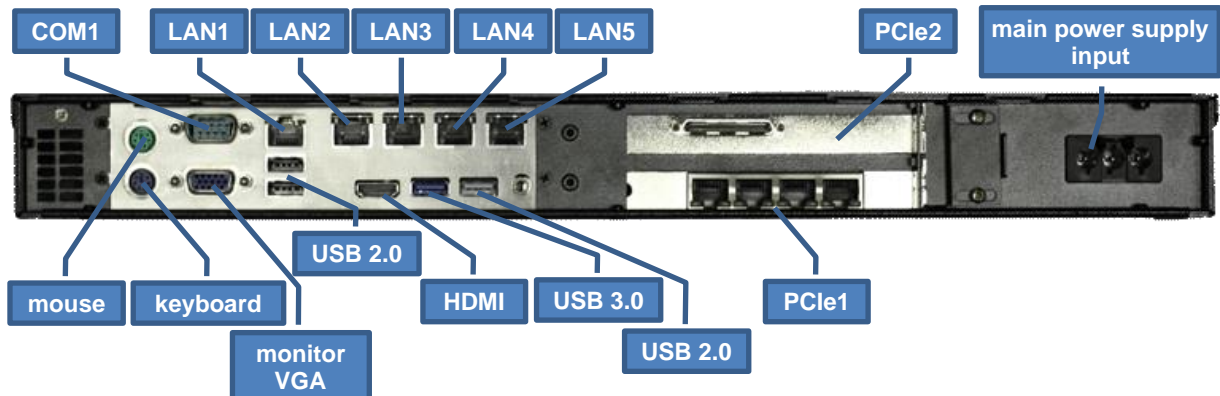

Figure 2: interfaces overview (example shows variant [E4M](#))

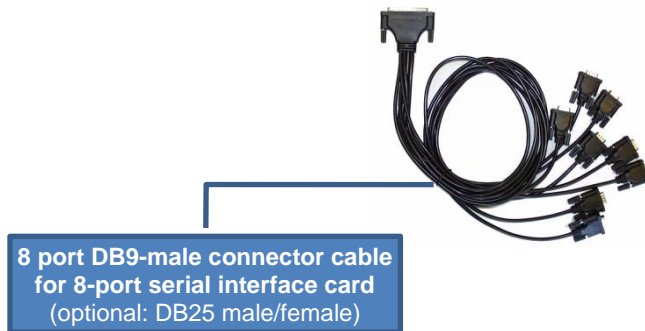

Figure 3: 8-port DB9-male connector cable for 8-port serial interface card

It is imperative to ensure a consequent strain relief to avoid damage to the connector, see figure above!

2.2 Hardware Components

2.2.1 Mainboard

The Mini-ITX Mainboard is an ultra-compact x86 platform with five integrated network interfaces und all other necessary interfaces. Its heart consists of a fanless Intel processor. The mainboard provides two DIMM slots for DDR3 memory modules and supports up to 8 GB system memory.

Additional interfaces:

- 2 x RS-232
- 2 x SATA
- 5 x LAN 10/100/1000 Mbps BaseT (RJ45)
- HDMI
- VGA
- Keyboard- / mouse port
- USB 2.0 and USB 3.0 connections (it is possible to order the deactivation of the USB interfaces on customer request)
- 2 x PCIe

2.2.2 Onboard RS-232 Interfaces

The installed mainboard provides 2 serial interfaces.

COM 1 – COM2

SERIAL PORT RS232 DTE DB9 male connector		Pin	Direction	Description
		1	INPUT	DCD Data Carrier Detect
		2	INPUT	RXD Receive Data
		3	OUTPUT	TXD Transmit Data
		4	OUTPUT	DTR Data Terminal Ready
		5		GND Masse
		6	INPUT	DSR Data Set Ready
		7	OUTPUT	RTS Request To Send
		8	INPUT	CTS Clear To Send
		9	INPUT	RI Ring Indicator

Figure 4: pin assignment of DB9 DTE RS-232 mainboard interface (COM1-COM2)

Note: For the adequate protection against the impact of switching interferences (Burst) and surge voltage, we recommend the use of our 4 kV isolated RS-232 isolator. The used RS-232 transceivers have ESD protection up to 15 kV. The isolator was tested according to EMC guidelines, climatic and mechanical requirements in compliance with the standard IEC 61850-3.

2.2.3 8/16 Port RS-232 Serial Interface (RS-232 Interface for Remote Communication)

Depending on the model each IPC191V4 can be equipped with up to two 8/16-port serial interface cards. The following pin assignment is realized with an 8-port DB9 male connector cable (see Figure 3). Other cables (e.g. DB25) are possible on request.

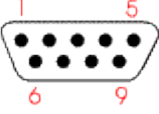
SERIAL PORT RS232 DTE DB9 male connector		Pin	Direction	Description
		1	INPUT	DCD Data Carrier Detect
		2	INPUT	RXD Receive Data
		3	OUTPUT	TXD Transmit Data
		4	OUTPUT	DTR Data Terminal Ready
		5		GND Masse
		6	INPUT	DSR Data Set Ready
		7	OUTPUT	RTS Request To Send
		8	INPUT	CTS Clear To Send
		9		

Figure 5: pin assignment of DB9 serial interface

See note chapter 2.2.2

2.2.4 Ethernet Interfaces

The industrial PC features five 10/100/1000 Mbps BaseT (RJ45) interfaces. Further interfaces with 10/100/1000 Mbps BaseT are possible on request. The IPC191V4 can be equipped with up to 13 Ethernet interfaces.

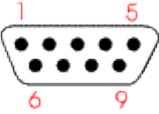
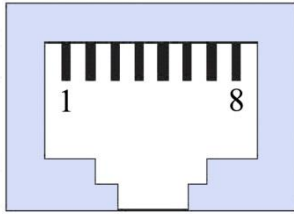

Figure 6: RJ45 network interface

2.2.5 CFast Memory Card

The CFast card serves as a mass storage device, i.e. for storing the operating system, the applications and configuration data. As a result the disadvantages involved with the use of a rotating hard disk are avoided, thus improving the reliability of the system substantially since a CFast has an MTBF of at least 4,000,000 hours.

The CFast adapter is simply connected to the SATA bus of the CPU module and treated just like a hard disk.

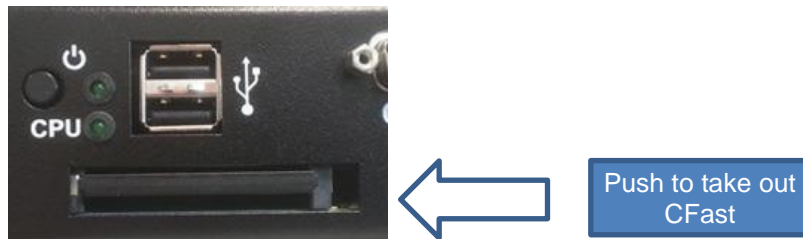

Figure 7: CFast adapter

When the power supply is switched off the CFast card with the entire software can simply be taken out or inserted enabling a quick change to different hardware.

It is possible to install the CFast card inside the device, inaccessible from the outside.

2.2.6 CMOS Lithium Battery

The onboard CMOS RAM stores system configuration data and has an onboard battery power supply. The long-life lithium battery has normally a lifetime of at least 5 years.

If the CMOS battery is empty and the CMOS information has been deleted, the CMOS-RAM is programmed by the BIOS with default settings.

The converter can be operated faultlessly even if the CMOS RAM is not provided by the battery. After the battery has been changed only time and date must be input.

For opening the case 6 screws on the top must be removed. The battery holder is soldered in the mainboard and well visible.

Attention: Open-frame power supplies are used. Because of this, the process should be carried out only by experienced electronic engineers. The device must be completely disconnected from any power supply. Before opening please push the power button (without electricity supply) several times to eliminate residual voltages of the power supply.

Battery replacement must be carried out by qualified specialists.

CAUTION! Incorrect replacement might cause the danger of explosion. Replace the battery exclusively by the same type (**3 V DC, CR2032**). Used batteries are to be disposed absolutely in accordance with the manufacturer's instructions.

Please pay attention to the correct polarity!

2.2.7 CPU LED

The CPU LED shows the states of conversion software and operating system.

Following figure shows all possible indications:

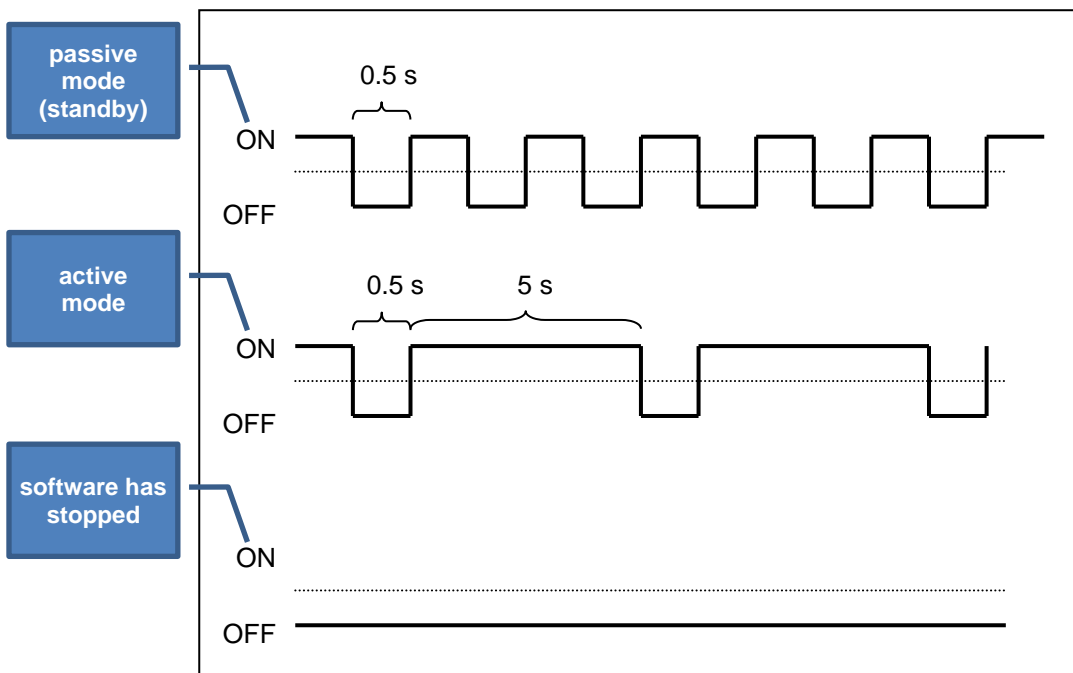

Figure 8: CPU LED indications

2.2.8 Power Supply

Power supplies with different input voltages can be used in the IPC191V4. Please pay attention to the correct polarity and input voltage. The input voltage of the respective device is labeled on top of the housing (see Figure 1).

2.2.8.1 AC Power Supply

By using AC voltages a specific power supply cable (see figure below) is supplied. Please use this cable exclusively:



Figure 9: power cable

2.2.8.2 DC Power Supply

By using DC voltages only a male connector is supplied. This connector has to be used. By connecting the cable with the male connector the correct polarity must be kept. The wire cross-section must be at least 1.5 mm².

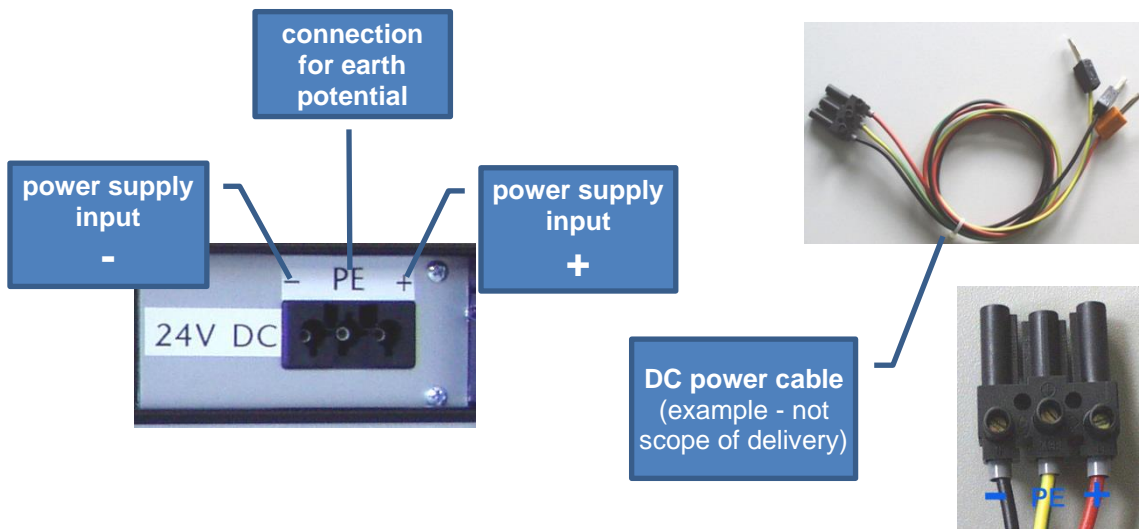

Figure 10: DC power connection socket

3 Overview of Variants / Interface Configuration

The following tables represent the configuration of the individual interfaces of miscellaneous variants.

3.1 Variant A

Assembly	Linux Device	I/O port	IRQ	Label	Connector
Mainboard	ttyS0	3F8	4	COM1 (Chassis rear)	DB9ST
	ttyS1	2F8	3	COM2 (Chassis front)	DB9ST
	eth0	PCIe (Onboard)	Auto	LAN1	RJ45
	eth1	PCIe (Onboard)	Auto	LAN2	RJ45
	eth2	PCIe (Onboard)	Auto	LAN3	RJ45
	eth3	PCIe (Onboard)	Auto	LAN4	RJ45
	eth4	PCIe (Onboard)	Auto	LAN5	RJ45
UART Adapter 8X	ttyMUE0	PCIe (Slot 2)	Auto	COM4	DB9ST
	ttyMUE1	PCIe (Slot 2)	Auto	COM5	DB9ST
	ttyMUE2	PCIe (Slot 2)	Auto	COM6	DB9ST
	ttyMUE3	PCIe (Slot 2)	Auto	COM7	DB9ST
	ttyMUE4	PCIe (Slot 2)	Auto	COM8	DB9ST
	ttyMUE5	PCIe (Slot 2)	Auto	COM9	DB9ST
	ttyMUE6	PCIe (Slot 2)	Auto	COM10	DB9ST
	ttyMUE7	PCIe (Slot 2)	Auto	COM11	DB9ST

Table 1: variant A

3.2 Variant B

Assembly	Linux Device	I/O port	IRQ	Label	Connector
Mainboard	ttyS0	3F8	4	COM1 (Chassis rear)	DB9ST
	ttyS1	2F8	3	COM2 (Chassis front)	DB9ST
	eth0	PCIe (Onboard)	Auto	LAN1	RJ45
	eth1	PCIe (Onboard)	Auto	LAN2	RJ45
	eth2	PCIe (Onboard)	Auto	LAN3	RJ45
	eth3	PCIe (Onboard)	Auto	LAN4	RJ45
	eth4	PCIe (Onboard)	Auto	LAN5	RJ45
UART Adapter 8X	ttyMUE0	PCIe (Slot 1)	Auto	COM4	DB9ST
	ttyMUE1	PCIe (Slot 1)	Auto	COM5	DB9ST
	ttyMUE2	PCIe (Slot 1)	Auto	COM6	DB9ST
	ttyMUE3	PCIe (Slot 1)	Auto	COM7	DB9ST
	ttyMUE4	PCIe (Slot 1)	Auto	COM8	DB9ST
	ttyMUE5	PCIe (Slot 1)	Auto	COM9	DB9ST
	ttyMUE6	PCIe (Slot 1)	Auto	COM10	DB9ST
	ttyMUE7	PCIe (Slot 1)	Auto	COM11	DB9ST
UART Adapter 8X	ttyMUE8	PCIe (Slot 2)	Auto	COM12	DB9ST
	ttyMUE9	PCIe (Slot 2)	Auto	COM13	DB9ST
	ttyMUE10	PCIe (Slot 2)	Auto	COM14	DB9ST
	ttyMUE11	PCIe (Slot 2)	Auto	COM15	DB9ST
	ttyMUE12	PCIe (Slot 2)	Auto	COM16	DB9ST
	ttyMUE13	PCIe (Slot 2)	Auto	COM17	DB9ST
	ttyMUE14	PCIe (Slot 2)	Auto	COM18	DB9ST
	ttyMUE15	PCIe (Slot 2)	Auto	COM19	DB9ST

Table 2: variant B

3.3 Variant E8

Assembly	Linux Device	I/O port	IRQ	Label	Connector
Mainboard	ttyS0	3F8	4	COM1 (Chassis rear)	DB9ST
	ttyS1	2F8	3	COM2 (Chassis front)	DB9ST
	eth0	PCIe (Onboard)	Auto	LAN1	RJ45
	eth1	PCIe (Onboard)	Auto	LAN2	RJ45
	eth2	PCIe (Onboard)	Auto	LAN3	RJ45
	eth3	PCIe (Onboard)	Auto	LAN4	RJ45
	eth4	PCIe (Onboard)	Auto	LAN5	RJ45
Ethernet Adapter 4X	eth5	PCIe (Slot 1)	Auto	LAN6	RJ45
	eth6	PCIe (Slot 1)	Auto	LAN7	RJ45
	eth7	PCIe (Slot 1)	Auto	LAN8	RJ45
	eth8	PCIe (Slot 1)	Auto	LAN9	RJ45
Ethernet Adapter 4X	eth9	PCIe (Slot 2)	Auto	LAN10	RJ45
	eth10	PCIe (Slot 2)	Auto	LAN11	RJ45
	eth11	PCIe (Slot 2)	Auto	LAN12	RJ45
	eth12	PCIe (Slot 2)	Auto	LAN13	RJ45

Table 3: variant E8

3.4 Variant E4M

Assembly	Linux Device	I/O port	IRQ	Label	Connector
Mainboard	ttyS0	3F8	4	COM1 (Chassis rear)	DB9ST
	ttyS1	2F8	3	COM2 (Chassis front)	DB9ST
	eth0	PCIe (Onboard)	Auto	LAN1	RJ45
	eth1	PCIe (Onboard)	Auto	LAN2	RJ45
	eth2	PCIe (Onboard)	Auto	LAN3	RJ45
	eth3	PCIe (Onboard)	Auto	LAN4	RJ45
	eth4	PCIe (Onboard)	Auto	LAN5	RJ45
Ethernet Adapter 4X	eth5	PCIe (Slot 1)	Auto	LAN6	RJ45
	eth6	PCIe (Slot 1)	Auto	LAN7	RJ45
	eth7	PCIe (Slot 1)	Auto	LAN8	RJ45
	eth8	PCIe (Slot 1)	Auto	LAN9	RJ45
UART Adapter 8X	ttyMUE0	PCIe (Slot 2)	Auto	COM4	DB9ST
	ttyMUE1	PCIe (Slot 2)	Auto	COM5	DB9ST
	ttyMUE2	PCIe (Slot 2)	Auto	COM6	DB9ST
	ttyMUE3	PCIe (Slot 2)	Auto	COM7	DB9ST
	ttyMUE4	PCIe (Slot 2)	Auto	COM8	DB9ST
	ttyMUE5	PCIe (Slot 2)	Auto	COM9	DB9ST
	ttyMUE6	PCIe (Slot 2)	Auto	COM10	DB9ST
	ttyMUE7	PCIe (Slot 2)	Auto	COM11	DB9ST

Table 4: variant E4M

3.5 Variant L

Assembly	Linux Device	I/O port	IRQ	Label	Connector
Mainboard	ttyS0	3F8	4	COM1 (Chassis rear)	DB9ST
	ttyS1	2F8	3	COM2 (Chassis front)	DB9ST
	eth0	PCIe (Onboard)	Auto	LAN1	RJ45
	eth1	PCIe (Onboard)	Auto	LAN2	RJ45
	eth2	PCIe (Onboard)	Auto	LAN3	RJ45
	eth3	PCIe (Onboard)	Auto	LAN4	RJ45
	eth4	PCIe (Onboard)	Auto	LAN5	RJ45

Table 5: variant L

3.6 Variant PSM

Assembly	Linux Device	I/O port	IRQ	Label	Connector
Mainboard	ttyS0	3F8	4	COM1 (Chassis rear)	DB9ST
	ttyS1	2F8	3	COM2 (Chassis front)	DB9ST
	eth0	PCIe (Onboard)	Auto	LAN1	RJ45
	eth1	PCIe (Onboard)	Auto	LAN2	RJ45
	eth2	PCIe (Onboard)	Auto	LAN3	RJ45
	eth3	PCIe (Onboard)	Auto	LAN4	RJ45
	eth4	PCIe (Onboard)	Auto	LAN5	RJ45
Profibus Adapter 1X		PCIe (Slot 1)	Auto	Profibus	Profibus Slave

Table 6: variant PSM

3.7 Variant PMM

Assembly	Linux Device	I/O port	IRQ	Label	Connector
Mainboard	ttyS0	3F8	4	COM1 (Chassis rear)	DB9ST
	ttyS1	2F8	3	COM2 (Chassis front)	DB9ST
	eth0	PCIe (Onboard)	Auto	LAN1	RJ45
	eth1	PCIe (Onboard)	Auto	LAN2	RJ45
	eth2	PCIe (Onboard)	Auto	LAN3	RJ45
	eth3	PCIe (Onboard)	Auto	LAN4	RJ45
	eth4	PCIe (Onboard)	Auto	LAN5	RJ45
Profibus Adapter 1X		PCIe (Slot 1)	Auto	Profibus	Profibus Master

Table 7: variant PMM

4 Technical Data

Diagnostic LEDs

- Power LED
- LED to show different software conditions
- HDD LED
- CFast activity LED

Mass storage CFast

- Rugged CFast card, industrial – grade
- Max. 64 GB supported
- MTBF \geq 4,000,000 hours
- No moving parts
- Removable flash card
- Bad Block Scanning/Handling
- Wear-Leveling system
- ECC
- Very short access time

Mass storage in removable frame (optional)

- SATA 2,5" SSD or HDD

Supported operating systems

- Linux

Additional functions

- Battery buffered real time clock (RTC)
- Watchdog

Standards

The device is CE certified and tested according to type of test
EN 61000-6-2: 2005
EN 61000-6-4: 2007+ A1:2011
EN 61000-3-2: 2006 + A1:2009 + A2:2009
EN 61000-3-3: 2008
(The test report is available on request.)

Housing

- 19" rack mount chassis (1U)
- 2x PCIe
- Excellent air flow with temperature controlled fans which are switched on only if a certain CPU temperature and system temperature respectively has been exceeded (configurable)

MTBF

> 100,000 hours

Power supply AC (delivery model 1 – standard)

- Fanless
- 90 – 264 V AC, 104 – 373 V DC auto range
- Starting current max. 30 A
- Input frequency 47 – 63 Hz
- Hold up time \geq 20 ms, 230 V AC
- Power consumption max. 50 W (depending on the used type)

**Power supply 24 V DC
(delivery model 2 – optional)**

- Fanless
- 9 – 32 V DC
- Starting current max. 30 A at 24 V DC
- Hold up time > 1 ms at +24 V DC and rated load
- Power consumption max. 50 W (depending on the used type)

Further power supplies available on request.

Mainboard

- Intel® Celeron® Embedded Quad-Core 64-bit processor, up to 2.16 GHz, passively cooled (up to 3x faster than CPU of IPC191V3)
- DDR3 RAM max. 8 GB
- SATA interface
- 2 serial ports
- Real-time clock/calendar
- 5 x RJ45 10/100/1000BaseT LAN interface, more on request (over PCIe)
- 6x USB (5x USB 2.0, 1x USB 3.0) (more on request)

Serial cards

- up to 32 RS-232 ports
- DB9 male connectors, optional RJ45, DB25 (male, female)
- Baud rate 50 bps to 921,600 bps
- 15 KV ESD protection
- optional 4 kV surge protection

Optical drive (optional)

CD/DVD writer with slot-in technology

Video

- Standard VGA interface
- HDMI interface (DVI possible with an adapter)

Dimensions

- Height 1 U
- 19" x 1.75" x 15" (W/H/D)
482.6 mm x 44.45 mm x 381 mm (W/H/D)

Weight

ca. 5.20 kg (depending on the used type)

Operating environment

- Operating temperature: 0° C to 50° C
- Storage temperature: 0° C to 60° C
- Relative humidity (non condensing): 5 % to 95 %

Assembled by IPCOMM GmbH / Germany

5 Nomenclature of the IPC191V4 article number

The IPC191V4 article number gives information about the equipment of the gateway.

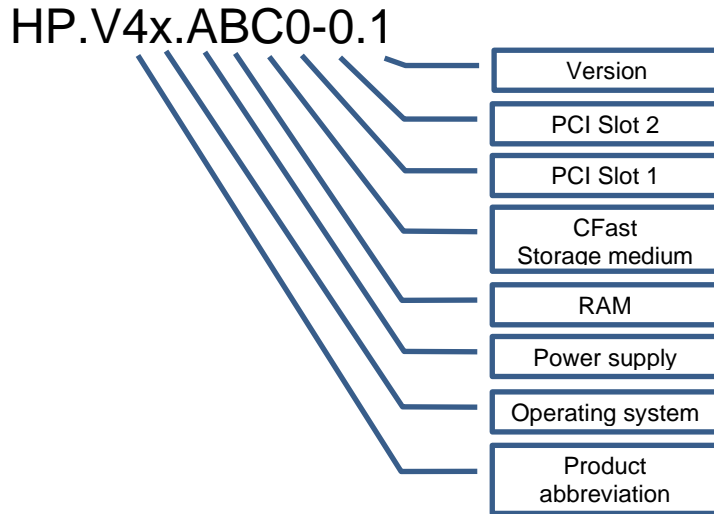

product abbreviation

Value	Description
I5	IPC191i5
V4	IPC191V4

operating system

Value	Description
L	LINUX
S1	Special model: - CFAST card installed inside the device - Deactivation of the USB interfaces

power supply

Value	Description
A	85 – 265 V AC
B	24 V DC
C	30 – 120 V DC

RAM

Value	Description
H	4 GB
I	8 GB

CFAST / storage medium

Value	Description
F	4 GB
G	8 GB
H	16 GB
I	32 GB
J	64 GB
S	Reserved (see SSD storage medium)

SSD

Value	Description
S1	64 GB
S4	120 GB

The combination of CFAST and SSD is hyphenated, e.g. D-S4 (CFAST = 1 GB, SSD = 120 GB)

PCI Slot 1/2

Value	Description
0	Not equipped
1	8port RS-232 interface card
2	Ethernet 4port
3	Ethernet 2port
4	4port RS-232 interface card
5	Ethernet 1port
6	Profibus Slave
7	Profibus Master
8	-
9	16port RS-232 interface card

6 IPC191 CAD Drawing

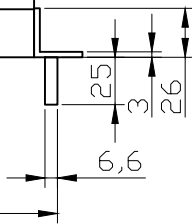
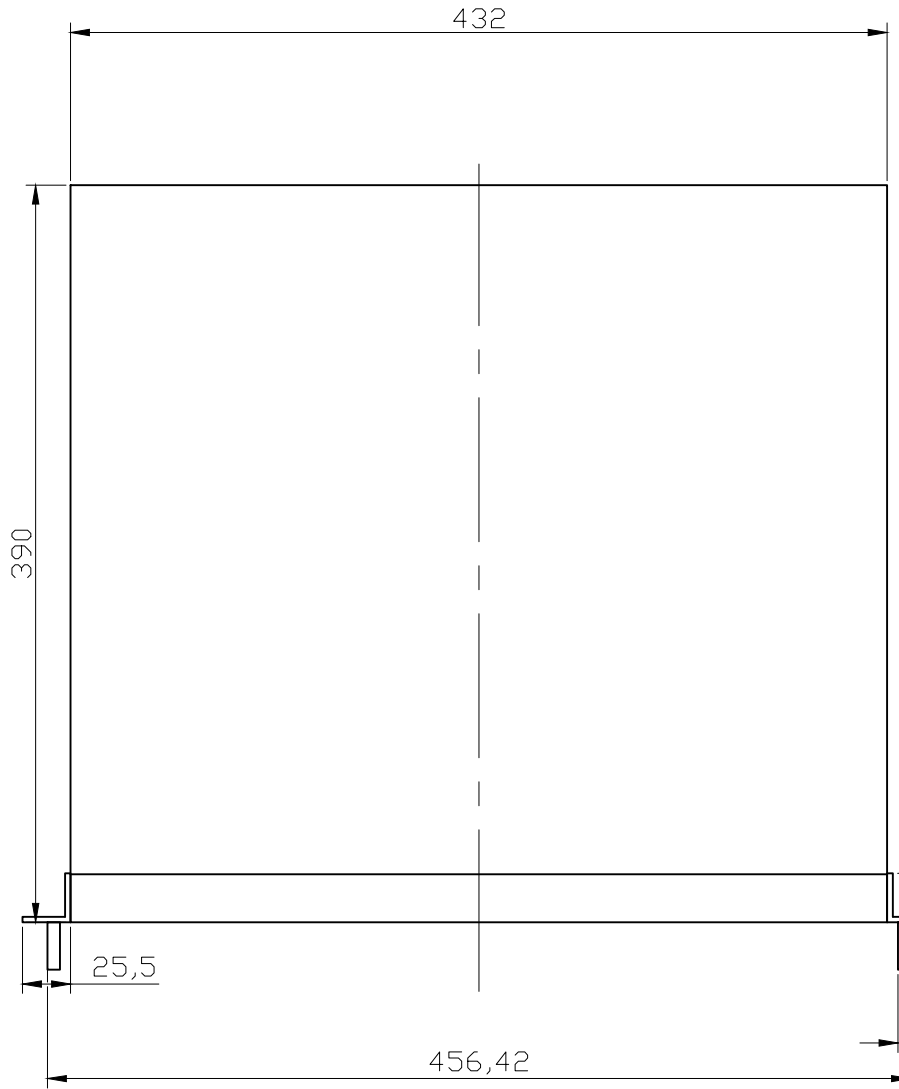
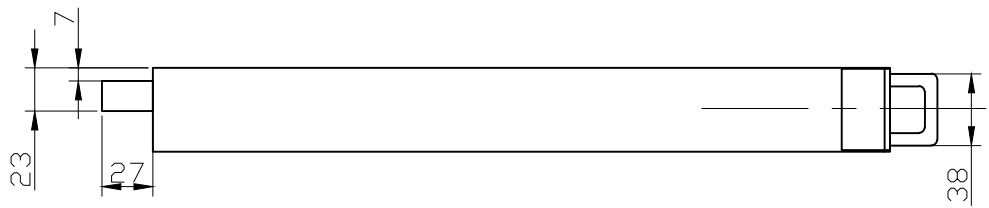
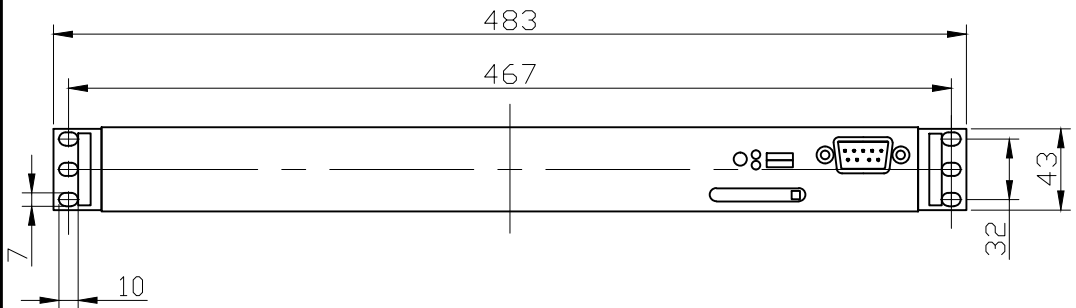

Subject to change without prior notice

General tolerance			Scale: 1 : 4
Designer	Date	Name	IPC191 19"
Checked	11.05.09	M. Ostapovski	
Standard			
IPCOMM GmbH		V 1.0	Page 1
Origin:	Repl. for:	Replaced through:	Pg.